

# **Stabilization of Bus Voltage and Reduction of Power Transmission Loss Based on the Fuzzy Reasoning**

Masahiro Inui, Du Hong, Makoto Ohki and Masaaki Ohkita  
Department of the Electrical and Electronic Engineering, Faculty of  
Engineering, Tottori University  
4-101 Koyama-Minami, Tottori, Tottori 680-8552 Japan  
Phone:+81-857-31-5699, Fax:+81-857-31-0880  
email: mohkita ele.tottori-u.ac.jp

**ABSTRACT:** In the power transmission system, the bus voltage has been controlled so as to be within the desired value which is preliminary set. The control has been implemented frequently by the switching control of the phase modifying equipment(PME). Actually, such a switching control has been performed based on the human experiments. Hence some times the bus voltage is out of its permissible operating range and the value of the reactive power increases which causes the power loss in the transmission lines. To improve such a difficulty, the authors have introduced the fuzzy reasoning in the switching control of the PME. Effectiveness of this method is shown with the simulation results.

**KEYWORDS:** Power transmission system, load transformer, phase modifying equipment, voltage control, reduction of power transmission loss, fuzzy reasoning.

## **1. INTRODUCTION**

In an electric power system, the fuzzy reasoning has been used for tap change control of the transformers, voltage adjustment of the generators and so on;1=;3=.

As for the voltage control is concerned, a phase modifying equipment (PME) has been used. The purpose of the control is to maintain the bus voltage of the substation to the desired values. For control of the bus voltage, the bus voltage is adjusted by reactive power value in the PME. In the conventional method, since the reactive power value is controlled only for the bus voltage stabilization, switching control of the reactive equipment does not operate in the vicinity of the upper and the lower bounds of the voltage so that the reactive power occurs sometimes in vain. In the case of such occurrence of reactive power and of existence of the long distance transmission line between the substations, the power loss between the line occurs.

In this paper, we propose a method to stabilize the bus voltage and, at the same time, to reduce the power loss in the transmission line by the reactive power control with an aid of the fuzzy reasoning.

## **2. CONTROL OF THE BUS VOLTAGE IN SUBSTATIONS**

### **2.1 THE CONVENTIONAL CONTROL EQUIPMENT**

In a high voltage power system with consumers of electricity of special high voltage and/or with the system whose secondary substation is located far from the primary substation, voltage at the load substation varies in cooperation with the load current variation. In such case, it is sometimes hard to maintain the bus voltage within its permissible operating range because of the limitation of the system management.

To improve such a difficulty, the PME is set and voltage control by the reactive power is frequently implemented. An example of control of the bus voltage by a PME is shown in Fig.1.

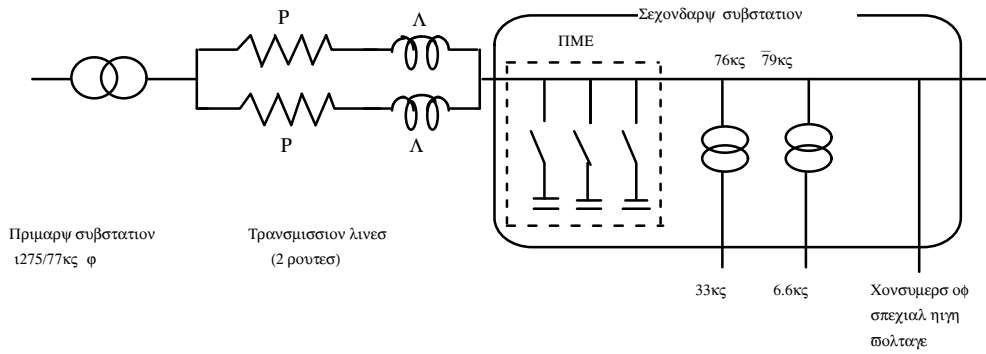

Figure 1: An example of control of the bus voltage by a PME

## 2.2 ACQUISITION OF THE OPERATING INFORMATION IN THE SUBSTATION

We had acquired the electrical data shown below in a power system from April 1997 to September 1997, about during six months. They are bus voltage, load current, power factor and switching timing of the static condensers and their average values in every two second.

## 2.3 PROBLEMS IN THE CONVENTIONAL CONTROL

In the conventional control, the switching timing of the PME is determined based on the difference between the desired values with the upper and lower bounds of the bus voltage and duration of the upper and lower excess values with respect to the bounds of the bus voltage. However, the equipment is not controlled suitably even in the vicinity of the upper and lower bounds of the bus voltage. This fact causes increase of the deviation between the maximum and minimum values of the bus voltage and the power transmission loss.

Examples of the actual data are shown in Fig.2. In this example, although the bus voltage shows the higher level than the reference voltage 77KV, and the unexpected reactive power more then 10MVAR is observed and it is not suppressed.

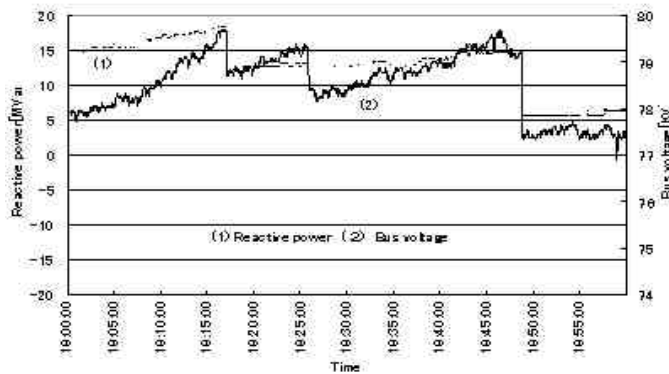

Figure 2: Examples of the actual voltage and reactive power.

## 3. CONTROL OF BUS VOLTAGE BY THE FUZZY REASONING

Our method is to aim at determination of the optimized reactive power so as to maintain the bus voltage within its permissible operating range and repress the occurrence of the reactive power with an aid of the fuzzy reasoning.

Concretely, this method performs the fuzzy reasoning with uncontrolled bus voltage and reactive power data, and determine the compensating coefficients of the switching timing for the PME,  $K_f; 1=$ . The value of  $K_f$  serves to make the bounds modify momentarily and continuously and determine the optimum reactive power so that the bus voltage is stabilized and the power transmission loss is reduced.

### 3.1 IMPLEMENTATION OF THE FUZZY REASONING

#### (1) Input variable

As the input variables, the value of the bus voltage and the reactive power are used.

#### (2) Control rules

The fuzzy control rules are shown in Fig. 3.

		Low	← Bus voltage →	High		
Lagging ↑ Reactive power ↓ Leading		NB	NM	ZO	PM	PB
	NB	PB	PB	PM	ZO	NM
	NM	PB	PM	ZO	ZO	NM
	ZO	PB	PM	ZO	NM	NB
	PM	PM	PM	ZO	NM	NB
	PB	PM	ZO	NM	NB	NB

Figure 3: Fuzzy control rules of the bus voltage and the reactive power.

#### (3) Membership functions

Procedures for the control operation are simulated in the C computer language and the membership functions are modified in their repetitive implementation.

The membership functions used are shown in the following.

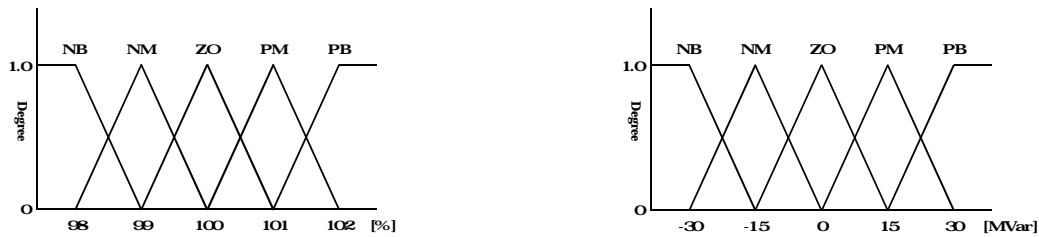

(a) Bus voltage (input)

(b) Reactive power(input)

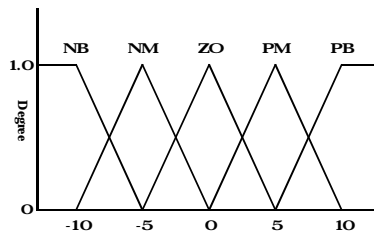

(c) Compensating coefficient for switching sensitivity, Kf (output)

Figure4. Membership functions

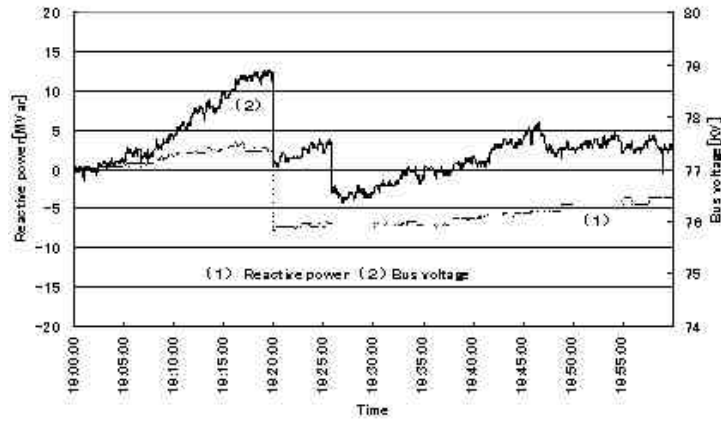

Table 1: Simulation results

Quantities of evaluation	Real system	Simulation results	Reduction of values
Maximum deviation of bus voltage (KV)	4.83	4.20	0.63
Average value of 30 minutes (%)	0.88	0.71	0.71
Power transmission loss (MW)	7.71	6.6	1.11

## 5. CONCLUSION

With an aid of the fuzzy reasoning, the switching timing of the PME is determined, which serves to stabilize the bus voltage of the substation and reduce the power transmission loss. The effectiveness of our method is proved through the numerical computation using the electrical data of the actual power system.

## REFERENCES

- [1] M.Inui and et.al.,1998," Tap-change control under a load transformer using fuzzy reasoning", Reports of the Faculty of Engineering, Tottori University, Vol.29,No.1,pp.45-51.
- [2] T.Takahashi and et.al.,1993," A new voltage control equipment using fuzzy inference ", Trans. Of IEE of Japan, Vol.113-B,No.1,pp.49-57.
- [3] T.Takahashi and et.al.,1993," Digital voltage adjusting relay with prospective control", General meeting of IEE of Japan, 1516, pp.11-108.