

TUNABLE DIGITAL HETERODYNE IIR FILTERS

Karl E. Nelson.

Electrical and Computer Engineering
University of California
One Shields Avenue
Davis, CA 95616

Michael A. Soderstrand

Head, Electrical and Computer Engineering
Room 202, Engineering South
Oklahoma State University
Stillwater, OK 74078

ABSTRACT

A new digital heterodyne filter is proposed that allow a prototype IIR or FIR filter to be shifted through the entire range of digital frequencies from DC to the Nyquist frequency. The unique properties of this new tunable filter are the range of tunability and the fact that all images created by the heterodyne process are cancelled. The proposed heterodyne filter is suitable both as a tunable filter and for use with standard adaptive algorithms to design adaptive digital filters --- especially adaptive notch filters.

1. INTRODUCTION

Digital Signal Processing has become a very important component of modern communications systems[1][2][3][4]. One very important issue is the removal of narrow-band interference from broad band BPSK and QPSK signals[5][6]. Recently several adaptive filter schemes have had success in the area of narrow-band interference attenuation[7][8]. In addition, narrow-band interference attenuation has been applied to electrical interference caused by mechanical resonance in control systems[9][10] using an adaptive lattice structure[8]. All of these applications point to the need for easily tunable filters that can be used to adjust a notch in order to attenuate some narrow-band interference. Recently a remarkable filter based upon using a heterodyne process to tune the filter was introduced [11]. In this paper, we introduce a modification to the filter previously proposed that drastically enhances the tunability of the filter and allows for a much more general set of base filters to be used in the tuning process. Most importantly, the new heterodyne filter proposed in this paper completely cancel out all of the filter images created by the heterodyne process.

2. DIGITAL HETERODYNE FILTER

2.1 Basic Concept

The basic idea of this research is to develop a general-purpose adaptive IIR filter that can adapt a filter by translation in the digital domain. To accomplish this a general structure needs to be developed which allows for the translation to occur.

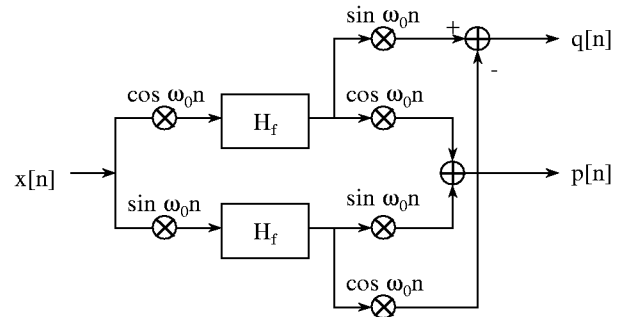

Figure 1. Basic heterodyne filter block

Direct translation without distortion of the amplitude and phase properties of the filter is not an easy task.

Translation of a filter can be achieved through a number of methods. The most direct approach is to compute the taps of the IIR filter to each new position. However, this is computationally undesirable. Further, small errors in the calculation could lead to some modes of the filter being unstable and unusable. Therefore, another solution must be found.

Our approach is to move the filter by moving the signal. The signal is translated by modulation with a carrier frequency in the digital domain to the center frequency of the filter. It is then filtered and retranslated back to its original position. The apparent effect is that the filter has been translated. Then a set of simple to design filters could be used in this translation filter to give the desired tunable effect.

2.2 Heterodyne Filter Block

In an early paper, we presented a adaptive version of a first order and second order IIR filter in the basic digital heterodyne structure[11]. Unfortunately, the original structure presented only maintains frequency characteristics for a relatively small number of IIR filters. Therefore, it is necessary to expand the original basic structure into one that works for all IIR filters.

Figure 1 is the basic structure used in the heterodyne filter. In this filter, stepping through two lookup tables containing sine and cosine generates a carrier frequency. This results in a linear oscillator whose frequency is fixed by size of the step.

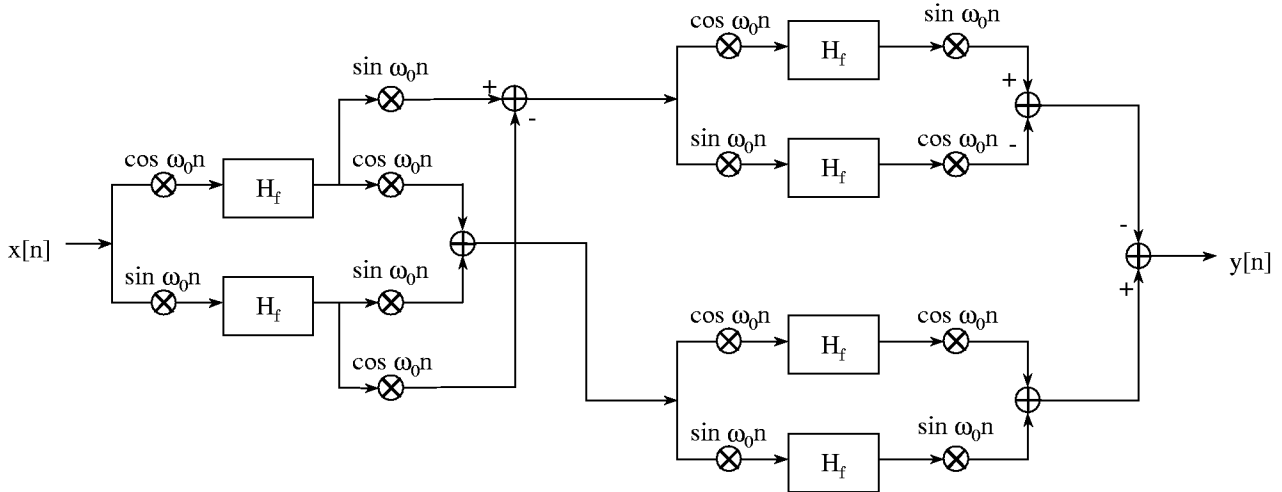

Figure 2. Full digital heterodyne filter

Nature mathematical reductions can be made to this table. Two identical copies of a fixed frequency IIR filter are used to process two out of phase copies of the signal generated through quadrature. These signals are then recombined using quadrature to form two outputs.

The outputs of this structure were derived assuming that the carrier frequency was constant and are given in the frequency domain as equation 1 and equation 2.

$$H_p(e^{j\omega}, \omega_0) = P(e^{j\omega})/X(e^{j\omega}) = 1/2 [H_f(e^{j(\omega-\omega_0)}) + H_f(e^{j(\omega+\omega_0)})] \quad (1)$$

$$H_q(e^{j\omega}, \omega_0) = Q(e^{j\omega})/X(e^{j\omega}) = 1/2j [H_f(e^{j(\omega-\omega_0)}) - H_f(e^{j(\omega+\omega_0)})] \quad (2)$$

The output P of this filter is therefore the sum of a filter translated up and down by the center frequency. In the case of a bandpass, this is the classic result from noise analysis.

However, this result has a number of problems in the digital domain. It is not usable for general-purpose notch filter, because the pass band from each of the two separate notches that result in the output will interfere with each other. This means the maximum depth of any notch filter using this will be 3dB. There are some filters in which a simple FIR filter can be brought around this filter to compensate for this distortion, but that is not a general result.

Band-pass operation of this filter is not effected by this problem. When a high-pass or low-pass filter with a sufficiently small pass band is placed in this filter the resulting output is a band-pass filter with twice the bandwidth.

When used in a digital spectrum other effects take place.

However, when the carrier frequency is within the size of the pass-band of 0 or π , the pass-bands will interfere with each other resulting in a large distortion of both the phase and magnitude responses. Although acceptable for some applications, it will prevent this filter form being used in a adaptive loop.

2.3 General Heterodyne Filter

To generalize the filter to work for an arbitrary fixed filter it is necessary to develop a filter with an equation closer to equation 3. This would then result in the multiplication of the amplitude response at all possible positions of the filter and the addition of the phase responses.

$$H(e^{j\omega}, \omega_0) = H_f(e^{j(\omega+\omega_0)}) H_f(e^{j(\omega-\omega_0)}) \quad (3)$$

Figure 2 shows a structure, which achieves exactly this. Three of the digital heterodyne blocks are cascaded to form a single output with the desired frequency response. The first full heterodyne filter block generates both outputs p[n] and q[n]. Each of the outputs is then run through another heterodyne filter block. The outputs generated from $H_p H_Q$ and $H_p H_Q$ are disregarded and the corresponding hardware has been removed.

The output of this filter can easily be verified as matching the desired filter response. In the frequency domain, the output of the filter is the difference between two H_p and two H_Q shown in equation 4.

$$H(e^{j\omega}, \omega_0) = H_p(e^{j\omega}, \omega_0) H_p(e^{j\omega}, \omega_0) - H_Q(e^{j\omega}, \omega_0) H_Q(e^{j\omega}, \omega_0) \quad (4)$$

Plugging in terms and reducing this equation yields the desired result, equation 3, without the need of an additional

and 14 variable multipliers. This may be too high for practical use in a tunable filter, so additional reductions need to be made later.

2.4 Fixed Filter Selection

With a workable filter translation system constructed, it is now possible to predict the available modes of operation to give the desired output. The primary mode of operation for this filter is that of a notch filter.

If a reasonably narrow high-pass or low-pass filter is used as a fixed filter in this system the resulting output will be a notch. A digital high-pass filter has its stop band centered about 0 by definition, so once translated its stop band will be centered about the carrier frequency. This makes for a nice notch filter with a linearly controllable center frequency. The bandwidth of the stop band of a high-pass is measured from 0 to its pass-band edge. However, the bandwidth of a notch is measured across the entire stop band, so the bandwidth of the resulting notch is double. In truth, we just changed definitions, but now the order of the filter is double.

Further, this resulting notch is completely stable regardless of the tuning of the filter. Once the modulation frequency passes Nyquist, it rolls over and appears to transition back from π to 0. The center of the notch follows exactly this effect. Assuming the internal filter is BIBO stable for all possible inputs and that the quadrature stages merely alters the input and output, the resulting notch filter is BIBO stable for all possible tunings. Coupled with the nature modulus effects of discrete time domain, this makes the filter stable at all times. Therefore, no limiters are required.

A similar mode of operation occurs if a low-pass filter is used with a small stop-band about π . This mode has all of the properties of the earlier one if π is added to the modulation frequency.

Another interesting mode of operation results when a high-pass or low-pass filter is used as the fixed frequency filter which has a cut off frequency at $\pi/2$. In this mode, the output is a tunable high-pass or low-pass filter. For the case of a fixed frequency high-pass filter, the output is a high-pass filter with a cut off frequency can be moved from $\pi/2$ to π corresponding to a modulation frequency of 0 to $\pi/2$. When the modulation frequency reaches $\pi/2$ a pass band appears about DC. This opens up to a low-pass filter which is tunable from DC to $\pi/2$ when the modulation frequency approaches π . Similar effects result from the use of a fixed frequency low-pass filter.

This filter has no modes that correspond to a band-pass output aside from a few special case notch filters in which the phase response across the filter permits subtraction of the input. Although these modes do exist, they can not be tailored in the same way that notch, low-pass and high-pass can.

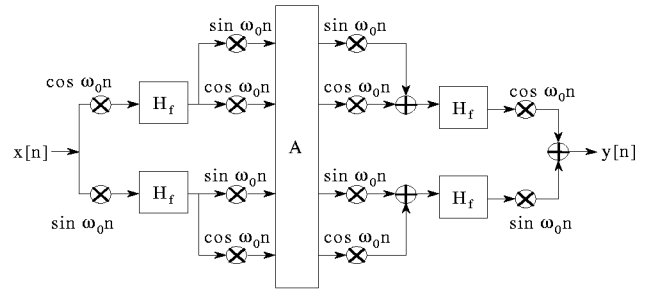

Figure 3. New tunable heterodyne filter

2.5 Structural Reductions

The first heterodyne stage split the signal into two out of phase versions. This was all that was needed to cancel images resulting from heterodyned images of the input traveling twice the carrier frequency. A derivation of this is presented in our last paper[11]. While at the same time, the general filter required four separate channels to achieve the same result. If only two channels are necessary for proper reconstruction then there must be some redundancy in these new stages.

Indeed, half the hardware in the last stage is redundant. By pushing the negative from the Q channel back through the multipliers, the second set of multipliers can be combined thus reducing the reconstruction to two channels. This is possible because although the heterodyne is not LTI, it is linear.

While the overall transfer function of this filter is LTI, the filter is not LTI in most stages. Except when measured from the outside or around the fixed frequency filter, the internal signals are linear only. However, with the recombination of the quadrature stage, we now have two identical LTI filters processing separate inputs then summing the output. Summing the inputs then applying the LTI filter can eliminate half of the filters in this stage.

The total cost of the design is now 4 times the fixed filter, a linear digital oscillator, and 12 multipliers. Although no further simplifications are possible, the filter may be arranged in such way that it become fully symmetric. This resulting filter is shown in Figure 3.

In this figure, a single matrix A, equation 5, containing ones and zeros represents the interconnections between the two stages. This is implemented with adders.

$$A = \begin{bmatrix} 1 & 0 & 0 & -1 \\ 0 & 1 & 1 & 0 \\ 0 & 1 & 1 & 0 \\ -1 & 0 & 0 & 1 \end{bmatrix} \quad (5)$$

This circuit can be tuned smoothly across the entire range from DC to the Nyquist frequency by simply adjusting the heterodyne frequency. Aside from use as a tunable filter, it can also be used to construct an adaptive filter by placing an LMS type algorithm in to control the heterodyne frequency.

3. EXPERIMENTAL RESULTS

3.1 Classical filters

Since the most practical application of this tunable notch filter is to create a notch from a classical IIR high-pass filter with desired amplitude and phase characteristics, it was necessary to verify the filter by inserting the "classic" IIR filters in to the structure and verify the outputs.

A number of classical filters were designed and tested in the notch mode of the digital heterodyne filter. A Butterworth, Chebychev type 1, Chebyshev type 2, and elliptical were each used. Each were designed to be of 8th order with a bandwidth of $\pi/16$. The desired floor for the elliptical and Chebychev were selected at 40 dB and a ripple of 0.5 dB. These filters were then probed with a digital impulse and the resulting outputs measured and transformed.

The resulting outputs were all notches with a bandwidth of $\pi/8$. Each was centered exactly at the modulation frequency. Thus the results were exactly as expected.

There were some effects apparent in the outputs of some note. Both the Chebychev and elliptical filters exhibited changes in the magnitude of the ripple in the pass band. At worst, the ripple increased to twice the original ripple of 0.5 dB. This effect results from interactions of the two frequency responses. The worst case occurred when the modulation frequency was zero with a ripple of 1 dB. For designs, it is recommended that the ripple in the pass band of the fixed frequency filter be designed to be one half of the desired ripple in the tunable filter.

3.2 Tunable Lowpass

To test the usability of the second mode of operation as a tunable low-pass filter, a 16th order low-pass Butterworth filter was placed in the heterodyne filter. The output was measure by probing with an impulse. Measurements were taken at modulation frequencies ranging from 0 to 0.49π .

The resulting output was a low-pass filter with tunable cutoff frequency from $\pi/2$ to 0. Some peaking about the Nyquist frequency was observed at a modulation frequency of 0.4π that increased to -10 dB by 0.49π . A higher modulation frequency transforms the filter into a tunable high-pass filter as expected.

4. SUMMARY

In this paper, we have proposed a new heterodyne digital filter that allows continuous tuning of a base-band prototype filter over a range from DC to the Nyquist frequency. The

heterodyne frequency is used to translate the center of the filter over the range of interest. The proposed structure offers the significant advantage that all of the images created by the heterodyne process are eliminated. Hence the filter seems to be unusually suited to applications where a tunable filter or an adaptive filter are needed without changes in bandwidth. In particular the structure should be well suited to applications that require the attenuation of narrow-band interference.

5. REFERENCES

- [1] K. Feher, *Advanced Digital Communications: Systems and Signal Processing Techniques*, Prentice-Hall, Inc., Englewood Cliffs, NJ, 1987.
- [2] K. Feher, *Wireless Digital Communications: Modulation and Spread Spectrum Applications*, Prentice-Hall, Inc., Englewood Cliffs, NJ, 1995.
- [3] W. Gao, M.A. Soderstrand and K. Feher, *Gaussian Filter Screens TDMA and Frequency-Hopping Spread-Spectrum Signals*, Microwave and RF, May 1995, pp. 17-19.
- [4] H. Yan, M.A. Soderstrand, J. Borowski and K. Feher, *DSP Implementation of GFSK, GMSK and FQPSK Modulated Wireless Systems*, RF Digital Communications, June 1995, pp. 28-32, June 1995.
- [5] M.A. Soderstrand, T.G. Johnson, R.H. Strandberg and H.H. Loomis, Jr., *Suppression of Multiple Narrow-Band Interference Using Real-Time Adaptive Notch Filters*, IEEE Transactions on Circuits and Systems, Vol. 44, No. 3, March 1997, pp. 217-225.
- [6] R.H. Strandberg, M.A. Soderstrand and H.H. Loomis, *Elimination of Narrow-Band Interference Using Adaptive Sampling Rate Notch Filters*, Proceedings 28th IEEE Asilomar Conference on Signals Systems and Computers, Pacific Grove, CA, October 1992, pp. 861-865.
- [7] R.H. Strandberg, J.C. Le Duc, L. G. Bustamante, V.G. Oklobdzija and M.A. Soderstrand, *Efficient Realizations of Squaring Circuit and Reciprocal used in Adaptive Sample Rate Notch Filters*, Journal of VLSI Signal Processing Systems for Signal, Image, and Video Technology, Vol 14, No. 3, December 1996, pp. 303-310.
- [8] L.G. Bustamante and M.A. Soderstrand, *Switched-Capacitor Adaptive Sample Rate Filter*, Proceedings 40th IEEE International IEEE Midwest Symposium on Circuits and Systems, Sacramento, CA, August 1997.
- [9] K.E. Nelson, P.V.N. Dao and M.A. Soderstrand, *A Modified Fixed-Point Computational Gradient Descent Gray-Markel Notch Filter Method for Sinusoidal Detection and Attenuation*, IEEE International Symposium on Circuits and Systems, Hong Kong, China, June 1997.
- [10] K.E. Nelson and M.A. Soderstrand, *Adaptive Filtering Using Heterodyne Frequency Translation*, Proceedings 40th IEEE International Midwest Symposium on Circuits and Systems, Sacramento, CA, August 1997.
- [11] K.E. Nelson and M.A. Soderstrand, *Adaptive Filtering Using Heterodyne Frequency Translation*, Proceeding 1998 IEEE Conference on Acoustics Speech and Signal Processing, Seattle, WA, June 1998.