

# Robust Reconfigurable Control for Parametric and Additive Faults with FDI Uncertainties

Zhenyu Yang *and* Jakob Stoustrup  
Department of Control Engineering  
Aalborg University

Fredrik Bajers Vej 7C, 9220 Aalborg, Denmark  
E-mail: yang, jakob@control.auc.dk

## Abstract

From the system recoverable point of view, this paper discusses robust reconfigurable control synthesis for LTI systems and a class of nonlinear control systems with parametric and additive faults as well as derivations generated by FDI algorithms. By following the model-matching strategy, an augmented optimal control problem is constructed based on the considered faulty and fictitious nominal systems, such that the robust control design techniques, such as  $H_\infty$  control and  $\mu$  synthesis, can be employed for the reconfigurable control design.

## 1 Introduction

The objective of Control Reconfiguration (CR) in the active fault tolerant control [6] is to recover the faulty system's performance/functionality to its nominal level by employing proper control techniques. With respect to different design strategies, the CR can be divided into two distinct categories: *requirement-oriented CR strategies* and *system-oriented CR strategies*. The first kind of CR strategies can be regarded as a kind of control design procedures, i.e., when some fault(s) happened inside the system, a new controller will be designed based on the faulty system information provided by FDI algorithms so as to make the reconfigured closed-loop system still satisfy the requirements originally proposed for the nominal system. This kind of strategy is intuitive and convenient to apply most of current control design methods into CR, however, it depends on concrete original system requirements. The second kind of strategy regards the CR as a kind of system's property recovery [2, 3, 4, 9], i.e., the CR design following this kind of strategy does not consider concrete system requirements, alternatively, the whole design is based on the inherent information of nominal and faulty systems so as to make these systems consistent in some proper senses. Due to the benefit of the essential dynamic/functionality recovery, the system-oriented CR strategies are causing more and more at-

tention in the fault tolerance research area.

From the system engineering point of view, the system-oriented CR strategies fit the model-following/matching scheme well if we regard the nominal systems as the reference models [1, 2, 3, 9]. Huang and R.F. Stengel proposed a restructurable control approach by using the implicit model-following method in [3]. Gao and P.J. Antsaklis gave a Pseudo-Inverse based method in [2] for a static feedback control redesign. Jiang discussed the acquisition of reconfigurable control by using eigenstructure assignment technique in [4]. Yang and M. Blanke employed the  $H_\infty$  control technique to discuss the recovery of system's I/O functionality in [9]. However, most current work focused on the CR synthesis is under assumption that

- the faulty system information is known or provided by FDI algorithm precisely, and/or
- the considered faults have a parametric form, i.e., these faults only have the effect of derivations on system dynamic parameters [6].

Actually, these assumptions are very *ad hoc* from the practical point of view. Firstly, in many cases the fault information provided by FDI algorithms to the CR procedure can not match exactly what the CR procedure expected, due to (1) the on-line computation of FDI algorithms requires some converging time before the estimated values approach the real ones; and (2) the FDI algorithms implemented in practical systems always will be disturbed by outside disturbances and system uncertainties. Secondly, most current model-based FDI approaches can only deal with *additive faults*, i.e., these faults only have an additive effect on the system inputs and/or outputs. Furthermore, many fault phenomena in practice manifest themselves not only as parametric forms, but also as additive ones in the system mathematical models. Recently, J. Stoustrup and H. Niemann proposed a FDI design approach for the parametric as well as additive faults by using a specific mixed  $\mu$  optimization in [8], which showed a possible way for integrated consideration of FDI and CR procedures.

Motivated by the work in [8, 9, 7], a novel approach for synthesis of robust reconfigurable control for the LTI and a class of nonlinear control systems is proposed in this paper, in order to deal with abrupt parametric faults as well as additive faults inside the systems. Besides that, the possible estimation errors generated by FDI algorithms, which we refer to as *FDI uncertainties*, are also considered in our approach. The main idea of this approach is to combine the nominal and faulty closed-loop systems into a fictitious augmented control system according to the model-matching strategy [1, 9], such that the  $H_\infty$  control and  $\mu$ -synthesis theories can be used for analysis and synthesis of the robust reconfigurable controllers.

## 2 Problem Formulation

Consider a class of continuous time LTI control systems with plant input and/or output disturbances, where the plant  $\mathcal{P}_n$  and controller  $\mathcal{K}_n$  have the forms:

$$\mathcal{P}_n : \begin{cases} \dot{x}_p(t) = A_p x_p(t) + B_p u_p(t) + E_p d(t), \\ y_p(t) = C_p x_p(t) + D_p u_p(t) + G_p d(t), \end{cases} \quad (1)$$

$$\mathcal{K}_n : \begin{cases} \dot{x}_c(t) = A_c x_c(t) + B_c u_c(t), \\ y_c(t) = C_c x_c(t) + D_c u_c(t), \end{cases} \quad (2)$$

Here  $x_p \in R^{n_p}$  ( $x_c \in R^{n_c}$ ) is the plant (controller) state vector,  $u_p \in R^{m_p}$  ( $u_c \in R^{m_c}$ ) is the plant control (controller input) vector,  $y_p \in R^{r_p}$  ( $y_c \in R^{r_c}$ ) is the plant (controller) output vector. The vector  $d \triangleq [\omega_a^T \ \omega_s^T]^T \in R^{n_a+n_s}$  is the stack of plant external disturbance signals, which includes the process input noise  $\omega_a \in R^{n_a}$ , and measurement noise  $\omega_s \in R^{n_s}$ . We assume  $\|d\|_2 \leq 1$ <sup>1</sup>. The plant and controller connect with each other into a closed-loop system through the relationship:

$$u_p(t) = u_{ref}(t) - y_c(t), \quad \text{and} \quad u_c(t) = y_p(t), \quad (3)$$

where  $u_{ref}(t)$  represents the reference signals. Equations (1),(2) and (3) define the *nominal closed-loop control system* in the following analysis. Furthermore, the nominal design is assumed to be well-posed.

When some fault(s) happened in the plant at time  $t_f$  with  $t_f > t_0$ , without loss of generality, we assume that the plant  $\mathcal{P}_n$  changes abruptly to the following form:

$$\mathcal{P}_f : \begin{cases} \dot{x}_f(t) = A_f x_f(t) + B_f u_p(t) + E_p d(t) + F f(t) \\ y_f(t) = C_f x_f(t) + D_f u_p(t) + G_p d(t) + H f(t) \end{cases} \quad (4)$$

Here the vector function  $f(t) \triangleq [f_a^T(t) \ f_i^T(t) \ f_s^T(t)]^T$  represents all the possible additive faults in the plant system, where subscript  $a, i, s$  represent the actuator, internal dynamic and sensor components, respectively. Assume there is  $f_k(t) \triangleq [f_{k1}(t) \ \cdots \ f_{km_k}(t)]^T$  with

<sup>1</sup>For the general case, a proper weighting function should be selected to make this assumption satisfied.

$f_{ki} \in \mathcal{R}$  for  $i = 1, \dots, m_k$  and  $k \in \{a, i, s\}$ , and denote the dimension of  $f(t)$  as  $r_f \triangleq am_a + im_i + sm_s$ . The additive fault matrices  $F$  and  $H$  represent the effect of these additive faults to the system internal and output dynamics respectively. In general, a filter  $W_f(s)$  can be found to satisfy:

$$f(t) \approx W_f(s) \tilde{f}(t), \quad \text{with the property: } \|\tilde{f}(t)\|_2 < 1. \quad (5)$$

If we include those fictitious states of the additive fault filter  $W_f(s)$  into the faulty system state expression, equation (4) describes this augmented system with property:  $\|\tilde{f}\|_2 < 1$ . In the following, we assume the considered system already has this kind of property.

Matrices  $A_f, B_f, C_f$  and  $D_f$  in (4) represent the faulty system matrices, which can be expressed as a (possibly nonlinear) dependency of a set of parameters as expressed in [8]:  $K_f \triangleq K_p + \sum_{i=1}^{n_k} h_i^k(\delta_1, \dots, \delta_q) K_i$ , where

$K$  represents symbol  $A, B, C, D$ , respectively. Each  $h_i^k$  are polynomial or real rational functions of parameter  $\delta_1, \dots, \delta_q$ , satisfying  $h_i(0, \dots, 0) = 0$ , which denotes the nominal operation mode. Each  $K_i$  will have only entries with 0 or 1.

In practice, there usually exists some possible estimation errors in the FDI information, which we refer to as *FDI uncertainties*. Assume these FDI uncertainties are also dependent on parameters  $\delta_1, \dots, \delta_q$ , i.e., all possible estimated values provided by FDI algorithms for corresponding faulty matrices have the expression:

$$K_f(\theta) \triangleq K_f + \sum_{i=1}^{n_k} g_i^k(\delta_1, \dots, \delta_q) K_i, \quad (6)$$

for  $K$  representing  $A, B, C, D$ , respectively. Here  $g_i^k$  are also polynomial or real rational functions of the parameter  $\theta \triangleq [\delta_1, \dots, \delta_q]^T$ , which we refer to as *FDI uncertainty functions*. When  $g_i^k \equiv 0$  for all  $k \in \{a, b, c, d\}$  and  $i = 1 \dots, n_k$ , it means that these faulty matrices mentioned in (6) are provided precisely by FDI algorithms. If the FDI mechanism is implemented by some “good” algorithms, these FDI uncertainty functions will have the property:

$$|g_i^k(\theta) K_i(l, j)| \ll |K_f(l, j)|, \quad \text{for } K_i(l, j) \neq 0. \quad (7)$$

The additive fault vector  $f(t)$  in equation (4) also needs to be provided by some FDI algorithms. As the discussion in (5) by using the fictitious filters, the possible estimation errors for additive faults  $f(t)$  can be transferred into the system matrices  $A_f(\theta), B_f(\theta), C_f(\theta), D_f(\theta)$  and additive fault matrices  $E(\theta)$  and  $F(\theta)$ , which have the similar forms as (6). Therefore, the faulty plant system provided by FDI es-

timination has the form:

$$\mathcal{P}_f(\theta) : \begin{cases} \dot{x}_f(t) = A_f(\theta)x_f(t) + B_f(\theta)u_p(t) + \\ E_p d(t) + F(\theta)f(t), \\ y_f(t) = C_f(\theta)x_f(t) + D_f(\theta)u_p(t) + \\ G_p d(t) + H(\theta)f(t). \end{cases} \quad (8)$$

Equations (8),(2) and (3) define the *faulty closed-loop control system with FDI uncertainties*.

In [8] a systematic modeling and synthesis procedure for the detection and isolation of these kind of parametric faults as well as additive faults has been proposed based on a mixed  $\mu$  optimization method. Here we consider the control reconfiguration problem based on the fault knowledge, i.e., in the following, we assume a set of fault system matrices, denoted as  $A_f, B_f, C_f, D_f, F, H$  as well as additive fault  $f(t)$  have already been provided by the FDI mechanism.

Let the transfer function matrix of the nominal closed-loop system from  $[u_{ref}^T \ d^T]^T$  to  $y_n$  be denoted as  $\mathcal{F}$ , and  $\mathcal{R}(\mathcal{K}_f, \theta)$  be the closed-loop transfer function matrix from  $[u_{ref}^T \ d^T \ f^T]^T$  to  $y_f$  for the case that a fault has occurred and the nominal controller  $\mathcal{K}_n$  has been redesigned as  $\mathcal{K}_f$  according to the FDI information. If we extend the transfer function matrix  $\mathcal{F}$  into matrix  $[\mathcal{F} \ 0_{r_p \times r_f}]$ , the latter matrix can be regarded as a transfer function matrix of the nominal closed-loop system from  $[u_{ref}^T \ d^T \ f^T]^T$  to  $y_n$ . Then the robust reconfigurable controller synthesis problem can be defined as: *Design a compensating system  $\mathcal{K}_f$  by solving the robust optimal problem*

$$\min_{\mathcal{K}_f \in \mathcal{R}_{ss}} \|([\mathcal{F} \ 0_{r_p \times r_f}] - \mathcal{R}(\mathcal{K}_f, \theta))\mathcal{W}\|_\infty \quad (9)$$

under the condition that the reconfigured closed-loop control system is internally stable with respect to the uncertainty  $\theta$ -term:  $\theta \in \Omega$ , where  $\mathcal{W}$  is a weighting function <sup>2</sup> and  $\Omega$  is the uncertainty set.

In situations where the optimum of (9) does not exist, (9) can be replaced by a corresponding suboptimal problem.

### 3 Synthesis of Robust Reconfigurable Control

In this section, we discuss the robust reconfigurable control synthesis by using the model-matching strategy[1, 9]. The main idea is to combine the nominal and faulty closed-loop systems together into a fictitious augmented control system, so that the  $H_\infty$  and  $\mu$  optimization methods can be used for the control synthesis.

<sup>2</sup>In practice,  $\mathcal{W}$  is also needed to be designed properly with respect to concrete problems.

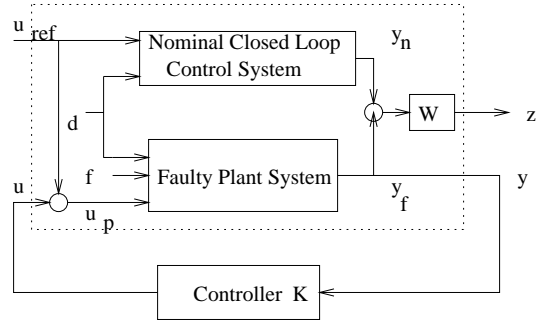

**Figure 1:** The Fictitious Augmented Control System

### 3.1 Synthesis without FDI Uncertainties

We assume that the FDI system can provide precise information, i.e., the functions  $g_i^k$  in (6) all equal zero for any  $k \in \{a, b, c, d, f, h\}$  and  $i = 1, \dots, n_k$ , respectively. We further assume that the additive fault vector  $f(t)$  already has the property<sup>3</sup>:  $\|f\|_2 < 1$ . Then equations (4),(2) and (3) define the faulty closed-loop control system before any reconfiguration.

Now we can construct an augmented control system by combining the nominal closed-loop system, the faulty plant system (4) and a new controller, which is denoted as  $\mathcal{K}$ . This fictitious augmented control system as shown in Fig.1 can be redrawn into a standard control system, therefore, it is obvious that the  $H_\infty$  optimal problem of this standard control system is to design a compensator  $\mathcal{K} \in \mathcal{R}_{ss}$  so as to solve the optimal (or a corresponding suboptimal) problem :

$$\min_{\mathcal{K}} \|\mathcal{F}(\mathcal{K})\mathcal{W}\|_\infty, \quad (10)$$

under the condition that the closed-loop system is internally stable, where  $\mathcal{F}(\mathcal{K})$  represents the transfer function matrix of the standard control system from  $[u_{ref}^T \ d^T \ f^T]^T$  to  $z$ .

In order to explore the conditions under which the faulty system makes the optimal problem (9) reasonable, following the robust control theory [1, 10] we have

**Lemma 1** [1]: The optimal solution  $\mathcal{K}$  for the augmented  $H_\infty$  optimization problem (10) exists if  $rank(N(j\omega))$  and  $rank([\overline{N} \ \overline{M}\mathcal{G}_{fd} \ \overline{M}\mathcal{G}_{ff}](j\omega))$  are constant for all  $0 \leq \omega \leq \infty$ . Where  $\mathcal{G}_{fd}, \mathcal{G}_{ff}$  and  $\mathcal{G}_{fu}$  represent the transfer matrices of faulty plant from input  $d, f$  and  $u$  to output  $y_f$ , respectively;  $M, N, \overline{M}, \overline{N}$  are the components of doubly-coprime factorization of  $\mathcal{G}_{fu}$ .

Consider that the fault information provided by FDI system maybe has state space forms like (6), we assume that the weighting function  $\mathcal{W}$  has already been included into the plant and controller modules, and

<sup>3</sup>Otherwise, the fictitious filter  $W_f$  is needed like (5).

the nominal closed loop system is stable and  $A_n$  has no eigenvalue on the imaginary axis, then we have

**Lemma 2** [10]: The optimal solution  $\mathcal{K}$  for the  $H_\infty$  optimization problem (10) exists, if

- The faulty system  $(A_f, B_f, C_f)$  is stabilizable and detectable;
- $D_f$  is full column rank, and  $[D_f \ G \ H]$  is full row rank;
- $A_n$  has no eigenvalues on the imaginary axis, and
- $\begin{bmatrix} A_f - j\omega & -B_f \\ -C_f & D_f \end{bmatrix}$  has full column rank;
- $\begin{bmatrix} A_f - j\omega & B_f & E & F \\ C_f & D_f & G & H \end{bmatrix}$  has full row rank.

**Theorem 1:** When the nominal closed-loop system, and the faulty plant (4) of the optimal  $\mathcal{K}_f$  synthesis problem (9) satisfy the conditions proposed in Lemma 1 or 2, the solution  $\mathcal{K}$  of the  $H_\infty$  optimization problem (10) is also a solution of the optimal  $\mathcal{K}_f$  synthesis problem (9).

**Remark 1:** In the  $H_\infty$  theory [10] the  $\gamma$ -suboptimal problem is usually used for the controller synthesis instead of the optimal problem (10). If we regard  $\gamma$  as a kind of quantitative evaluation of the reconfiguration level, the infimum  $\gamma^*$  represents the best reconfiguration level that a LTI controller can achieve with respect to the provided faulty system structure.

### 3.2 Synthesis with FDI Uncertainties

When the FDI uncertainties are considered, i.e., some functions of  $g_i^k$  in (6) are non-zero, equations (8),(2) and (3) define the *faulty closed-loop control system with FDI uncertainties* before any reconfiguration.

It can be noted that the considered FDI uncertainties (6) exhibit as a kind of parametric system uncertainties. In order to employ standard robust control techniques for optimal synthesis problem (9), these parametric uncertainties need to be transferred into feedback-forms by the Linear Fractional Transformation (LFT) [10]. Consider the  $\theta$ -parametric matrix  $A_f(\theta)$  as shown in (8), which has the form:

$$A_f(\theta) \triangleq A_f + \sum_{i=1}^{n_a} g_i^a(\delta_1, \dots, \delta_q) A_i.$$

Denote the term with zero order of  $\theta$  in function  $g_i^a(\delta_1, \dots, \delta_q)$  as  $g_{i0}^a$  for  $i = 1, \dots, n_a$ , then with respect to the polynomial/real-rational forms of  $g_i^a$  and LFT theory [10], the parametric matrix  $A_f(\theta)$  can be represented as an upper LFT form, i.e.,

$$A_f(\theta) = \mathcal{F}_u(M_A, \Delta_A), \quad \text{where} \quad (11)$$

$$M_A \triangleq \begin{bmatrix} M_{11}^a & M_{12}^a \\ M_{21}^a & A_M \end{bmatrix}, \quad A_M \triangleq A_f + \sum_{i=1}^{n_a} g_{i0}^a A_i, \quad \text{and}$$

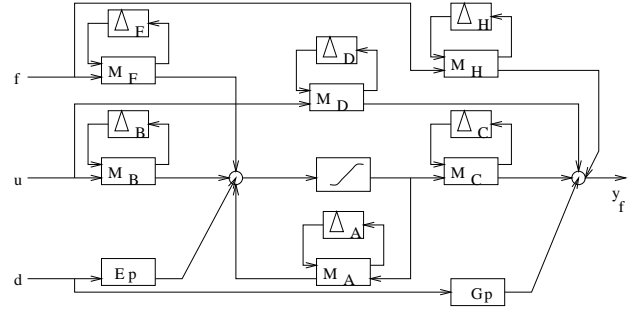

**Figure 2:** Faulty Plant with FDI Uncertainties

$$\Delta_A \triangleq \text{diag}(\delta_1 I_{r_1^a}, \dots, \delta_q I_{r_q^a}), \quad (12)$$

Here  $r_i^a$  is the highest order of parameter  $\delta_i$  in function  $g_j^a(\delta_1, \dots, \delta_q)$  for  $j = 1, \dots, n^a$ ,  $i = 1, \dots, q$ . Denote  $r_{\Delta_A} \triangleq r_1^a + r_2^a + \dots + r_q^a$ , and  $r_A \triangleq \text{dim}(A_f)$ , then the partition of the matrix  $M_A$  follows  $(r_{\Delta_A} + r_A) \times (r_{\Delta_A} + r_A)$ . Matrices  $M_{11}^a$ ,  $M_{12}^a$  and  $M_{21}^a$  in (12) are determined by concrete forms of functions  $g_i^a$  for  $i = 1, \dots, n^a$ . Similarly, the parametric matrices  $B_f(\theta)$ ,  $C_f(\theta)$ ,  $D_f(\theta)$ ,  $F(\theta)$  and  $H(\theta)$  can also be represented as an LFT form as (11) and (12). Therefore, the faulty plant (8) can be expressed as the form:

$$\begin{bmatrix} \dot{x}_f \\ y_f \end{bmatrix} = \begin{bmatrix} \mathcal{F}_u(M_A, \Delta_A) & \mathcal{F}_u(M_B, \Delta_B) \\ \mathcal{F}_u(M_C, \Delta_C) & \mathcal{F}_u(M_D, \Delta_D) \\ E_p & \mathcal{F}_u(M_F, \Delta_F) \\ G_p & \mathcal{F}_u(M_H, \Delta_H) \end{bmatrix} \begin{bmatrix} x_f \\ u \\ d \\ f \end{bmatrix}, \quad (13)$$

which system structure is shown in Fig.2.

With respect to the LFT properties [10], equation (13) can be expressed in a more compacted form:

$$z = \mathcal{F}_u(\mathcal{M}_p(s), \Delta_p) w \quad (14)$$

where  $w \triangleq [d^T \ f^T \ u^T]^T$  and  $z \triangleq y_f$ , and

$$\mathcal{M}_p \triangleq \mathcal{F}_u(M_p, \frac{1}{s} I_{r_A}), \quad \text{with} \\ M_p \triangleq \begin{bmatrix} A_M & N_1 & E_p & F_M & B_M \\ N_2 & N_3 & 0 & N_4 & N_5 \\ C_M & N_6 & G_p & H_M & D_M \end{bmatrix} \quad \text{and} \quad (15)$$

$$\Delta_p \triangleq \text{diag}(\Delta_A, \Delta_B, \Delta_C, \Delta_D, \Delta_F, \Delta_H), \quad (16)$$

here matrices  $N_1, \dots, N_6$  in (15) are determined by  $M_{11}^k$ ,  $M_{12}^k$  and  $M_{21}^k$  for  $k \in \{a, b, c, d, f, h\}$ , respectively.

The reconfigured closed-loop control system is a feedback combination of the plant (14) with a new controller  $\mathcal{K}_f$ , which needs to be synthesized. If we denote the transfer function matrix of reconfigured closed-loop system from  $w$  to  $z$  as  $\mathcal{R}(\mathcal{K}_f, \theta)$ , it has an LFT form:

$$\mathcal{R}(\mathcal{K}_f, \theta) = \mathcal{F}_l(\mathcal{F}_u(\mathcal{F}_u(M_p, \frac{1}{s} I_{r_A}), \Delta_p), \mathcal{K}_f). \quad (17)$$

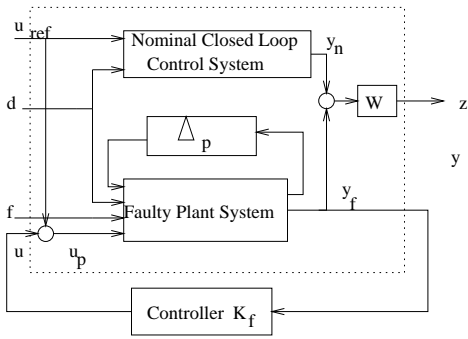

**Figure 3:** The Augmented Control System

The new controller  $\mathcal{K}_f$  in (17) should satisfy the optimal problem (9). In order to employ the robust control synthesis techniques to solve this problem, a fictitious augmented control system is constructed by combining the nominal closed-loop system and faulty closed-loop system (17) together as shown in Fig.3. This augmented control system can be further redrawn into a standard robust control problem with system uncertainty  $\Delta_p$ , where the state variable of the standard plant is  $[x_n^T \ x_f^T]^T$  and the external input variable is  $[d^T \ f^T \ u_{ref}^T]^T$ . Denoted this standard plant as  $\tilde{\mathcal{P}}(s)$ , then, with respect to the small gain theorem with structured uncertainties [10], we have:

**Theorem 2:** Given a real positive scalar constant  $\gamma > 0$ , if there exists a real rational controller  $\mathcal{K}_f$ , which combines with the faulty plant system (8) satisfying  $\|\mathcal{F}_l(\tilde{\mathcal{P}}, \mathcal{K}_f)\|_\mu < \gamma$ , then the reconfiguration error of I/O functionality is bounded by:

$$\|y_n - y_f(\theta, \mathcal{K}_f)\|_2 < \gamma\beta, \quad (18)$$

where  $\beta$  is the excitation level of the system, i.e.,  $\|[u_{ref}^T \ d^T \ f^T]^T\|_2 = \beta$ .

**Remark 2:** The robust reconfigurable controller  $\mathcal{K}_f$  can be synthesized by standard  $\mu$  synthesis technique, such as the D-K iteration and/or LMI methods. However, it should be noted that these methods do not guarantee a global optimum will be found.

#### 4 Extension for Nonlinear Control Systems

In this section, we extend the proposed synthesis method to deal with a class of continuous time nonlinear control systems as shown in Fig.4, which was proposed originally in [7] for FDI design. here we assume there is no any system disturbance ( $d(t) \equiv 0$ ) and FDI uncertainties<sup>4</sup>.

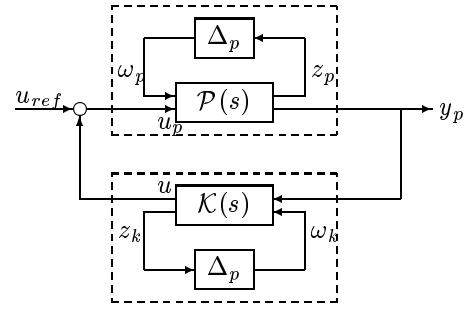

**Figure 4:** A Class of Nonlinear Control Systems

#### 4.1 Problem Description

The considered nonlinear system as shown in Fig.4 contains two components: the upper dash-box is the nonlinear plant, which includes two interconnecting parts: the linear part  $\mathcal{P}(s)$  with inputs:  $u_p$  and  $\omega_p$ , and outputs:  $z_p$  and  $y_p$ ; and the nonlinear part  $\Delta_p$ . Usually,  $\mathcal{P}(s)$  can be thought of as the linearization of the plant in some operating point. The lower dash-box is the nonlinear controller. According to the methods in [5, 7], this nonlinear controller is a combination of a linear part  $\mathcal{K}(s)$  which is designed by the standard linear system theory and a nonlinear part  $\Delta_p$  which is the copy of the nonlinear part of the plant.

We assume there is  $\Delta_p \in \mathbf{\Delta} = \{\Delta \mid \Delta \in \mathcal{H}_\infty, \|\Delta\|_\infty < \gamma, \text{ where } \gamma \text{ is a positive constant}\}$ . By employing the LFT theory [10], we can get a compact expression of the system which is defined as  $\mathcal{P}_n^{non} \triangleq \mathcal{F}_u(\mathcal{G}_n, \Delta_n)$ , where  $\omega_n \triangleq [\omega_p^T \ \omega_k^T]^T$ ,  $z_n \triangleq [z_p^T \ z_k^T]^T$ ,  $\Delta_n \triangleq \begin{bmatrix} \Delta_p & 0 \\ 0 & \Delta_p \end{bmatrix}$ , and  $\begin{bmatrix} z_n \\ y_p \end{bmatrix} \triangleq \begin{bmatrix} G_{n11} & G_{n12} \\ G_{n21} & G_{n22} \end{bmatrix} \begin{bmatrix} \omega_n \\ u_{ref} \end{bmatrix}$ .

When some fault happened inside the (nonlinear) plant, assume which can be indicated by derivations of the transfer matrices  $G_{nij}$  ( $i, j = 1, 2$ ) and  $\Delta_p$  respectively, then we can get the faulty nonlinear control system (without any reconfiguration), denote which as  $\mathcal{P}_f^{non} \triangleq \mathcal{F}_u(\mathcal{G}_f, \Delta_f)$ .

In order to deal with the nonlinear control reconfiguration problem, the robust control mixer method proposed in [9] originally for LTI systems is extended in the following. The basic idea of using the control mixer method is that: When some fault occurred inside the nonlinear control systems, instead of redesigning the nonlinear controller, some new dynamical (LTI-form) modules, which are referred to as *control mixer modules*, will be inserted into the closed-loop system so as to try to recover the reconfigured system as the same as the nominal one in the  $H_\infty$ -norm sense.

<sup>4</sup>The proposed method can be extended directly to deal with the cases  $d \neq 0$  and with FDI uncertainties.

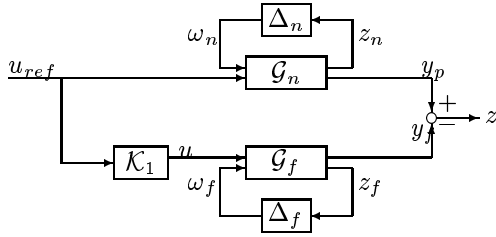

**Figure 5:** The augmented System by Using  $\mathcal{K}_1$

#### 4.2 Synthesis of Robust Control Mixer Module

As stated in [9], there are many possible inserting locations for the control mixer modules, which depend on the concrete systems and problems. In order to show our method without triviality, here we just consider the case of using one pre-compensator - called control mixer module  $\mathcal{K}_1$  in [9] - for the nonlinear control reconfiguration design as shown in the low part of Fig.5. Then, the optimal synthesis problem for module  $\mathcal{K}_1$  can be formulated as: designing a compensating system  $\mathcal{K}_1$  by solving the optimal (or corresponding suboptimal) problem

$$\min_{\mathcal{K}_1 \in \mathcal{R}_{ss}} \|\mathcal{F} - \mathcal{F}_f \mathcal{K}_1\|_\infty, \quad (19)$$

under the condition that the reconfigured closed-loop system is internally stable subject to the nonlinear parts  $\Delta_n$  and  $\Delta_f$ .

By following the same procedure for LTI systems in Section 3, a fictitious augmented nonlinear control system can be constructed as shown in Fig. 5. Obviously, this augmented control system can be transferred into a standard robust control configuration, where the closed-loop transfer matrix from  $u_{ref}$  to  $z$  can be denoted as  $\mathcal{R}(\mathcal{K}_1) \triangleq \mathcal{F}_l(\mathcal{F}_u(\mathcal{G}_1, \Delta_1), \mathcal{K}_1)$  with  $\Delta_1 \triangleq \begin{bmatrix} \Delta_n & 0 \\ 0 & \Delta_f \end{bmatrix}$ ,  $\omega_1 \triangleq [\omega_n^T \ \omega_f^T]^T$ ,  $y \triangleq u_{ref}$  and  $z_1 \triangleq [z_n^T \ z_f^T]^T$ , and the standard plant  $\mathcal{G}_1$  has the form

$$\begin{bmatrix} z_n \\ z_f \\ z \\ y \end{bmatrix} = \begin{bmatrix} G_{n11} & 0 & G_{n12} & 0 \\ 0 & G_{f11} & 0 & G_{f12} \\ G_{n21} & -G_{f21} & G_{n22} & -G_{f22} \\ 0 & 0 & I & 0 \end{bmatrix} \begin{bmatrix} \omega_n \\ \omega_f \\ u_{ref} \\ u \end{bmatrix}$$

Therefore, the optimal control mixer  $\mathcal{K}_1$  design problem can be replaced by a standard robust control problem, i.e.,  $\min_{\mathcal{K}_1} \|\mathcal{F} - \mathcal{F}_f \mathcal{K}_1\|_\infty = \min_{\mathcal{K}_1} \|\mathcal{R}(\mathcal{K}_1)\|_\infty$ , under the condition that the closed-loop system is internally stable subject to the structured system uncertainty  $\Delta_1$ .

**Remark 3:** The proposed method can also be extended to deal with parametric and additive faults as well as FDI uncertainties for the considered nonlinear systems. In those situations, the FDI uncertainties  $\Delta_A, \Delta_B, \Delta_C, \Delta_D, \Delta_F$  and  $\Delta_H$  as defined in (12) need to join the nonlinear parts  $\Delta_p, \Delta_{pf}$  so as to construct a

new uncertainty part  $\Delta_1$  in the augmented control system. For the consideration of additive faults  $f$  and/or system disturbance  $d$ , the system transfer function matrices  $\mathcal{F}$  and  $\mathcal{R}(\mathcal{K}_1)$  need to be extended as those from  $[u_{ref}^T \ d^T \ f^T]^T$  to  $y_p/y_f$  as we did in Section 2 (9).

## 5 Conclusions

A novel approach for synthesis of robust reconfigurable control for LTI systems and a class of nonlinear control systems with parametric and additive faults as well as uncertainties generated by FDI algorithms has been proposed in a unified framework. The  $H_\infty$  control and  $\mu$  synthesis techniques can be employed efficiently for this control synthesis by following the model-matching strategy. To investigate the integration of the proposed CR method with the robust FDI method proposed in [8] for the whole fault tolerant control design will be the subject of our future work.

## References

- [1] B.A. Francis, "A Course in  $H_\infty$  Control Theory", *LNCIS*, Springer-Verlag, 1987.
- [2] Z. Gao and P.J. Antsaklis, "Stability of the Pseudo-Inverse Method for Reconfigurable Control Systems", *Int. J. Control*, Vol.53, No.3 Mar. 1991, pp717-729.
- [3] C.Y. Huang and R.F. Stengel, "Restructurable Control Using Proportional-Integral Implicit Model Following", *J. Guid. Contr. & Dyn.*, Vol.13, No.2, 1990, pp303-309.
- [4] J. Jiang, "Design of Reconfigurable Control Systems Using Eigenstructure Assignments", *Int. J. Contr.*, Vol.59, No.2, 1994.
- [5] A. Packard, "Gain Scheduling via Linear Fractional Transformations", *Systems & Control Letters*, Vol.22, 1994, pp.79-92.
- [6] R.J. Patton, "Fault-Tolerant Control: The 1997 Situation", *Proc. SAFEPROCESS'97*, Hull, UK, 1997, pp1033-1055
- [7] J. Stoustrup and H.H. Niemann, "Fault Detection for Nonlinear Systems - A Standard Problem Approach", *Proc. 37th CDC*, Dec. 1998, pp96-101.
- [8] J. Stoustrup and H.H. Niemann, "Fault Detection and Isolation in Systems with Parametric Faults", *Proc. IFAC World Congress*, Beijing, Jul. 1999, Vol.P, pp.139-144.
- [9] Z. Yang and M. Blanke, "Robust Control Mixer Module Method for Control Reconfiguration", *Proc. ACC2000*, Chicago, USA, Jun. 2000.
- [10] K. Zhou, J.C. Doyle and K. Glover, "Robust and Optimal Control", Prentice Hall, 1996.