

Spatially localized convolution kernels for feedback control of transitional flows

Markus Högberg^{1,2} AND Thomas R. Bewley¹

¹ *Dynamic Systems & Control Group, Dept. of MAE, UC San Diego, La Jolla, CA, USA*

² *Dept. of Mechanics, Royal Institute of Technology, Stockholm, Sweden*

Presented at the 39th IEEE Conference on Decision and Control, Dec. 2000, Sydney, Australia.

Optimal (\mathcal{H}_2) linear feedback controllers are computed for the Orr–Sommerfeld/Squire equations for an array of wavenumber pairs $\{k_x, k_z\}$ and then inverse-transformed to the physical domain, as recommended by Bewley & Liu (JFM **365**, 1998) and using the general method outlined therein. The feedback kernels so computed are effective at minimizing both transient energy growth and the relevant input-output transfer function norms in the controlled linear system representing small perturbations to a laminar channel flow.

The important new result of the present paper is the demonstration that this calculation yields feedback convolution kernels with localized support in the physical domain. These localized kernels eventually decay exponentially with distance from the actuator location, allowing them to be truncated a finite distance from each actuator while retaining any desired degree of accuracy in the feedback computation. The truncated, spatially compact convolution kernels may then be used in decentralized control implementations on the distributed flow system. Spatial localization of $\mathcal{H}_2/\mathcal{H}_\infty$ feedback for this type of system was predicted theoretically by Bamieh, Paganini, & Dahleh (IEEE TAC, submitted) and D’Andrea & Dullerud (IEEE TAC, submitted) in related work. Spatial localization provides the critical link which connects controllers designed for the (artificial) spatially periodic model system to application on physical systems, which are spatially evolving. Unfortunately, not all formulations of the present control problem lead to physical-space controllers with localized spatial support.

The feedback convolution kernels so determined are then implemented in direct numerical simulations of transitional flows with both random and oblique-wave finite magnitude initial flow perturbations, per the cases of particular physical significance enumerated by Reddy *et al.* (JFM **365**, 1998). The ability of the linear control feedback to stabilize the nonlinear flow system is demonstrated for finite initial flow perturbations with magnitudes well beyond the threshold which induces transition to turbulence in the uncontrolled system.

I. INTRODUCTION

The process of transition of a laminar flow to turbulence is only partially understood. This process is of central importance in many practical engineering systems involving fluid flows; recent reviews on this active research topic can be found in Trefethen *et al.* (1993), Berlin, Wiegel, & Henningson (1999), and Schmid & Henningson (2000). Feedback control strategies designed to delay or eliminate transition which have been based on this limited physical understanding have been largely unfruitful. The present work is one in a series of several investigations to derive transition control strategies directly from first principles, bypassing phenomenological descriptions of transition which are still incomplete. Actuation via a distribution of wall-normal blowing and suction over the walls is chosen as a canonical problem—the derivation of control schemes utilizing more practical actuation strategies should follow from this work as a straightforward extension. It is also assumed in the present work that the

entire state of the system can be measured; the problem of state estimation is dual to the control problem considered here, and will be addressed in a future paper. It is hoped that this research, in addition to providing direct information about how laminar to turbulent transition may be effectively controlled, will also provide indirect evidence about the nature of the physical phenomenon of transition itself by identifying the fluid motions targeted by effective control strategies.

II. OBJECTIVE: PREVENT TRANSITION

The objective of the present study is to minimize the energy growth (due to the non-normality of the stable linear system) from nonzero, finite-amplitude initial conditions in order to prevent transition to turbulence. The minimization of transfer function norms quantifying the flow response to both structured and unstructured external disturbances is closely related, as discussed by Be-

wley & Liu (1998). In sub-critical flows which are linearly stable, the non-normal nature of the operators governing the evolution of the system lead to mechanisms for very large transient energy growth (Butler & Farrell 1992) and, thereby, nonlinear instability due to small initial flow perturbations of particularly deleterious structure. In this paper, we make an important step towards showing how flow perturbations with sufficiently large magnitude to induce such nonlinear instability may be inhibited by the application of decentralized linear feedback control.

The mechanisms for energy growth in the uncontrolled system are strictly linear, as the nonlinear terms in the equation governing the system only redistribute the energy between different modes of flow perturbations. This observation motivates application of linear control feedback to the finite but small perturbations leading to nonlinear instability in transitional flows; if the linear control feedback stabilizes the system in the correct way, transient energy growth will be reduced, and thus both large flow perturbations and nonlinear instability will be avoided. This observation has also motivated some researchers to speculate about the possible application of linear control feedback to the large-amplitude flow perturbations present in turbulent flows (Farrell & Ioannou 1993). Further speculation in this regard is deferred to Bewley (1999), and will be discussed further in the context of the present control formulation in a future paper.

III. MODEL SYSTEM: PERIODIC CHANNEL

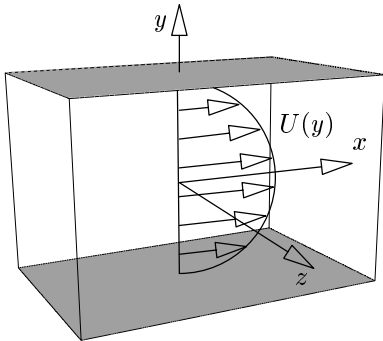

FIG. 1. Geometry of the flow domain.

Small perturbations $\{u, v, w\}$ to a laminar flow $U(y)$ in a channel (Figure 1) are governed by the Orr-Sommerfeld/Squire equations. These equations are derived from the Fourier transform (in the x and z directions) of the Navier-Stokes equation linearized about a mean flow profile $U(y)$, and may be written at each wavenumber pair $\{k_x, k_z\}$ as

$$\Delta \hat{v} = \{-i k_x U \Delta + i k_x U'' + \Delta(\Delta/Re)\} \hat{v} \quad (1a)$$

$$\hat{\omega} = \{-i k_z U'\} \hat{v} + \{-i k_x U + \Delta/Re\} \hat{\omega}, \quad (1b)$$

where $\Delta \equiv \partial^2/\partial y^2 - k_x^2 - k_z^2$ and hat ($\hat{\cdot}$) denotes Fourier coefficients. The Reynolds number $Re = U_c h/\nu$ param-

eterizes the problem, where h is the half-width of the channel, U_c is the centerline velocity, and ν is the kinematic viscosity of the fluid. Without loss of generality, we assume the walls are located at $y = \pm 1$.

At each wavenumber pair, a state vector may be defined by discretization of the wall-normal velocity \hat{v} and the wall-normal vorticity $\hat{\omega}$ on several grid points in the y direction. A Chebyshev collocation technique is used in the y direction with differentiation matrices obtained from the Matlab Differentiation Matrix Suite of Weideman & Reddy (1999). Boundary conditions are handled in the construction of the differentiation matrices in such a way that spurious eigenvalues are eliminated, as suggested by Huang and Sloan (1993). Invocation of the homogeneous boundary conditions on $\partial \hat{v}/\partial y$ (resulting from the no-slip condition $\hat{u} = \hat{w} = 0$ at the wall and the continuity equation $ik_x \hat{u} + \partial \hat{v}/\partial y + ik_z \hat{w} = 0$) allows inversion of the Laplacian on the LHS of (1a) and expression of (1) in matrix form:

$$\underbrace{\begin{pmatrix} \dot{\hat{v}} \\ \dot{\hat{\omega}} \end{pmatrix}}_{\dot{\mathbf{x}}_f} = \underbrace{\begin{pmatrix} \mathcal{L} & 0 \\ \mathcal{C} & S \end{pmatrix}}_N \underbrace{\begin{pmatrix} \hat{v} \\ \hat{\omega} \end{pmatrix}}_{\mathbf{x}_f}. \quad (2)$$

Control is applied via blowing and suction at the channel walls. A lifting technique is used to formulate the control equations in state-space form. To accomplish this, decompose the flow perturbation such that

$$\mathbf{x}_f = \mathbf{x}_i + \mathbf{x}_h. \quad (3)$$

The inhomogeneous part \mathbf{x}_i is taken to satisfy the nonzero boundary conditions and numerically convenient equations on the interior of the domain; in the present case, we choose the steady-state equation $N\mathbf{x}_i = 0$. Assembling the controls (*i.e.*, the values of the \hat{v} at the upper and lower walls) into a control vector ϕ , this system may easily be solved for arbitrary ϕ and written as

$$\mathbf{x}_i = Z\phi. \quad (4)$$

The part \mathbf{x}_h therefore satisfies homogeneous boundary conditions, and the interior equation governing \mathbf{x}_h may be found by substitution of (3) into (2). Noting (4), the result may be written

$$\underbrace{\begin{pmatrix} \dot{\mathbf{x}}_h \\ \dot{\phi} \end{pmatrix}}_{\dot{\mathbf{x}}} = \underbrace{\begin{pmatrix} N & NZ \\ 0 & 0 \end{pmatrix}}_A \underbrace{\begin{pmatrix} \mathbf{x}_h \\ \phi \end{pmatrix}}_{\mathbf{x}} + \underbrace{\begin{pmatrix} -Z \\ I \end{pmatrix}}_B \underbrace{\dot{\phi}}_{\mathbf{u}}$$

We have arrived at the desired state-space form. Note that the control \mathbf{u} is the *time derivative* of the normal velocity at the upper and lower walls, and the state \mathbf{x} is the control ϕ appended the homogeneous vector \mathbf{x}_h . Note also that, for the convenient lifting we have defined and used here, we may take $NZ = 0$ in the above expression, since $N\mathbf{x}_i = NZ\phi = 0$.

The energy in the flow perturbation is measured as the integral of the square of the velocities over the flow domain. Rewriting the energy measure in $v - \omega$ form gives

$$E = \frac{1}{2} \int_{\Omega} (u^2 + v^2 + w^2) d\Omega = \frac{1}{2} \int_{\Omega} (v^2 - \Delta v^2 + \omega^2) d\Omega,$$

which, incorporating Parseval's theorem, is easily written in matrix form as $E = \mathbf{x}_f^* Q \mathbf{x}_f$ for the contribution from each wavenumber pair. Noting the decomposition (3), the energy of the flow perturbation at each wavenumber pair may be written in terms of the state variable \mathbf{x} as

$$E = \mathbf{x}^* \begin{pmatrix} Q & QZ \\ Z^*Q & Z^*QZ \end{pmatrix} \mathbf{x} \triangleq \mathbf{x}^* Q \mathbf{x}.$$

IV. OPTIMAL CONTROL STRATEGY

We now seek the control \mathbf{u} which, with limited control effort, minimizes the flow perturbation energy on $t \in [0, \infty)$. This is a standard optimal control problem. Defining the objective function

$$J = \int_0^{\infty} (\mathbf{x}^* Q \mathbf{x} + \ell^2 \mathbf{u}^* \mathbf{u}) dt,$$

the control \mathbf{u} which minimizes J is given by

$$\mathbf{u} = K \mathbf{x}, \quad \text{where } K = -\frac{1}{\ell^2} B^* X$$

and where X is the positive definite solution to the Riccati equation

$$XA + A^* X - XB \frac{1}{\ell^2} B^* X + Q = 0.$$

Note that ℓ^2 is used as an adjustable parameter which scales the penalty on the control effort in the cost function, and that this penalty term is a function of $|\phi|^2$ in the present formulation. Due to the continuity of the velocity field, excursions of $|\phi|^2$ are penalized naturally in the $\mathbf{x}^* Q \mathbf{x}$ term of the cost function, and no additional penalty on $|\phi|^2$ was found to be necessary in the present work.

The optimal control problem described above has been derived for each wave number pair $\{k_x, k_z\}$ independently. By assembling the corresponding physical space controller via an inverse Fourier transform, we may derive feedback convolution kernels that can be used to compute the control input in the physical domain. The convolution integral by which the control is computed in physical space is given by

$$\phi_{\pm 1}(x, z) = \int_{\Omega} \left(k_{v, \pm 1}(x - \bar{x}, \bar{y}, z - \bar{z}) v(\bar{x}, \bar{y}, \bar{z}) + k_{\omega, \pm 1}(x - \bar{x}, \bar{y}, z - \bar{z}) \omega(\bar{x}, \bar{y}, \bar{z}) \right) d\bar{x} d\bar{y} d\bar{z}$$

where $k_{v, \pm 1}$ and $k_{\omega, \pm 1}$ are the result of the inverse Fourier transform of the feedback gains on v and ω respectively.

V. RESULTS

Linear analysis

The linearized system may be analyzed at each wavenumber pair separately due to the complete decoupling of the problem at distinct wavenumber pairs when the control problem is formulated correctly. Upon performing such an analysis, it is seen that the feedback kernels computed via the present strategy significantly reduce both transient energy growth and the relevant input-output transfer function norms in the controlled linear system representing small perturbations to a laminar channel flow, as documented in detail by Bewley & Liu (1998).

Spatial localization

As shown in Figures 2 and 3, the feedback convolution kernels for v and ω computed using the technique described above are found to be spatially localized with exponential decay far from the actuator. This exponential decay implies that they can be truncated with a prescribed degree of accuracy at a finite distance from each actuator, arriving at spatially compact convolution kernels that can be computed and applied in a decentralized fashion on arbitrarily large arrays of sensors and actuators. Note that, for the kernels shown in Figures 2 and 3, the kernels were computed at $Re = 4196$ for a $4\pi \times 2 \times 2\pi$ box at a resolution of $170 \times 90 \times 170$ modes with $\ell = 1$, and a mean flow profile $U(y) = 1 - y^2$ was used.

Note that the convolution kernels for both v and ω angle away from the wall in the upstream direction. Coupled with the mean flow profile indicated in Figure 1, this accounts for the convective delay required to anticipate flow perturbations on the interior of the domain with actuation on the wall somewhere downstream.

The convolution kernels shown in Figures 2 and 3 are independent of the box size in which they were computed, so long as the computational box is sufficiently large. Thus, for the purpose of implementation, we may effectively assume that they were derived in an *infinite*-sized box, thereby relaxing the nonphysical assumption of spatial periodicity used in their calculation. Further, the feedback gains in the present work are well behaved at high spatial wavenumbers; the physical-space convolution kernels are well resolved on computational grids which are appropriate for the simulation of the physical system of interest.

Direct Numerical Simulations of the nonlinear Navier–Stokes equation (using the DNS code benchmarked by Bewley, Moin, & Temam 2000) were first used to confirm the results from linear analysis, showing good agreement in terms of maximum transient energy growth for small initial perturbations. For oblique wave and initially random flow perturbations with energy densities of $225\times$ and $15\times$ (respectively) the transition thresholds reported by Reddy *et al.* (1998), the controller prevents transition and brings the flow back to the laminar state, as shown in Figure 4. The simulations reported here have been performed at $Re = 2000$. The initial energy density for the oblique waves is $5.275 \cdot 10^{-4}$ plus 1% random noise. For the random disturbance, the initial energy density is $1.025 \cdot 10^{-3}$. The box size is $2\pi \times 2 \times 2\pi$ with sufficient resolution – the same as that used to compute the transition thresholds by Reddy *et al.* (1998) – to resolve the flows under consideration. In the uncontrolled simulations, both initial conditions lead to transition to turbulence, whereas for the controlled system the flows are returned to the laminar state. For the controlled cases shown in Figure 4, initial conditions with even higher energy fail to relaminarize, while initial conditions with lower energy relaminarize earlier.

VI. DISCUSSION

Physical systems lack spatial periodicity

Transition phenomena in physical systems, such as boundary layers and plane channels, are not spatially periodic, though it is often useful to characterize the response of such systems with Fourier transforms. Application of Fourier-space controllers which assume spatial periodicity in their formulation to physical systems which are not spatially periodic, as proposed by Cortelezzi & Speyer (1998), will be corrupted by Gibbs phenomenon, the well-known effect in which a Fourier transform is spoiled across all frequencies when the data one is transforming is not itself spatially periodic.

In order to correct for this phenomenon in formulations which are based on Fourier-space computations of the control, windowing functions such as the Hanning window are appropriate. Windowing functions filter the measured signals such that they are driven to zero near the edges of the physical domain under consideration, thus artificially imposing spatial periodicity on the non-spatially periodic measurement vector. In essence, such windowing functions impose a degree of spatial compactness (of a width equal to some fraction of the full width of the spatial domain under consideration) on control feedback rules which are not themselves naturally spatially localized, significantly corrupting the control feedback computation.

Though the windowing approach suggested above might alleviate the corruption due to Gibbs phenomenon in the application of Fourier-space feedback control to non-spatially periodic systems, application of such control strategies (via on-line FFTs of the complete measurement vector and inverse FFTs of the complete control vector) still require centralized controllers. For massive arrays of actuators in distributed spatially invariant systems, it is highly desirable to localize the computation of the feedback to functions of nearby state variables only, rather than requiring centralized coordination of the entire system, which becomes unmanageable both in terms of computational and communication requirements as the array size grows. Physical-space convolution kernels with compact spatial support lend themselves naturally to decentralized control. Fourier-space feedback computations, which require on-line FFTs and iFFT, do not.

VII. CONCLUSIONS

Spatially localized convolution kernels for the feedback control of transitional flows have been determined. These kernels have been found via inverse Fourier transform of a set of optimal feedback controllers determined for the Orr-Sommerfeld/Squire system on an array of wavenumber pairs $\{k_x, k_z\}$. The kernels have been shown to effectively prevent transition in the Direct Numerical Simulation of the nonlinear Navier-Stokes equation for initial conditions which rapidly lead to transition to turbulence when feedback control is not applied. These localized kernels eventually decay exponentially with distance from the actuator location, allowing them to be truncated a finite distance from each actuator while retaining any desired degree of accuracy in the feedback computation. The truncated, spatially compact convolution kernels may then be used in decentralized control implementations on the distributed flow system.

The importance of the spatial localization of the present result, and the subsequent truncation to spatially compact kernels with finite support which this localization facilitates, can not be over-emphasized. This is the critical link which connects feedback controllers determined for artificial, spatially periodic model systems to implementable, spatially compact feedback kernels applicable for the decentralized control of physical, spatially evolving distributed flow systems.

Acknowledgments

The authors thank Dan Henningson, Bassam Bamieh, and Scott Miller for useful discussions related to this work, and Satish Reddy for providing the initial conditions for the transition simulations.

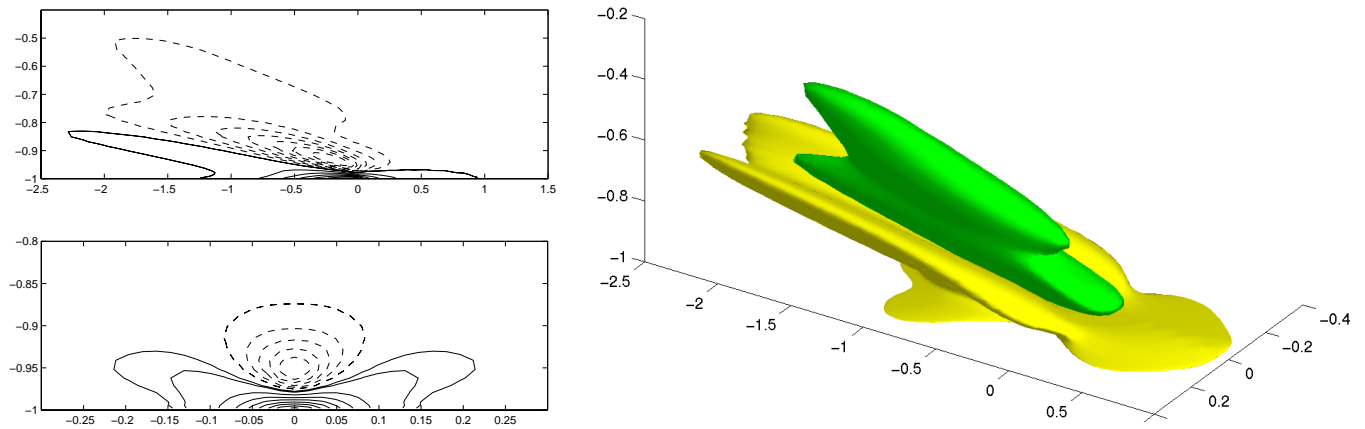

FIG. 2. Physical-space feedback convolution kernel for v . Contours in an xy plane at $z = 0$ (top) and a zy plane at $x = 0$ (bottom) are shown on the left (positive contours solid, negative contours dashed), and two isosurfaces of the convolution kernel are shown on the right (one positive and one negative).

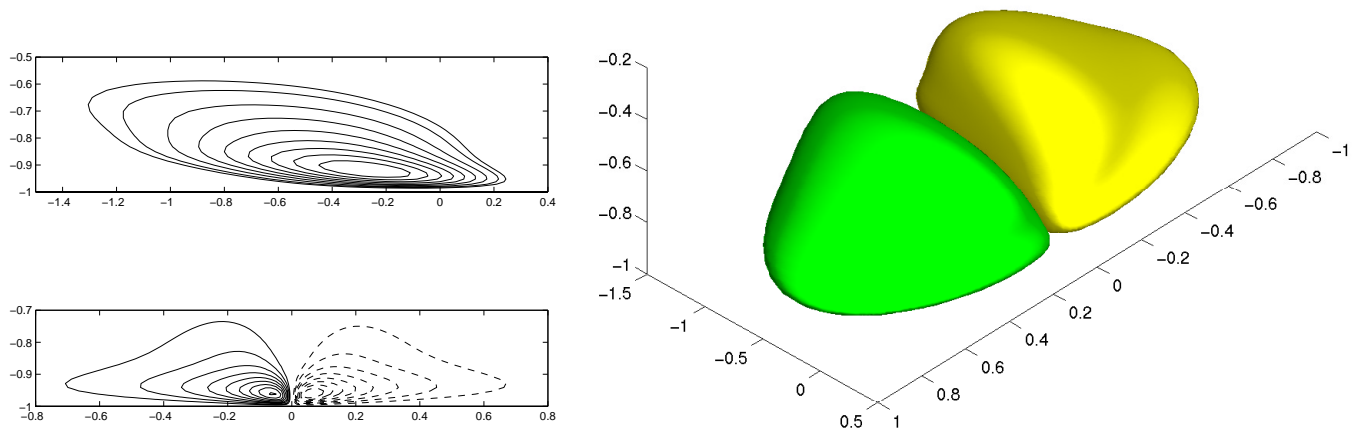

FIG. 3. Physical-space feedback convolution kernel for ω . Contours of an xy plane at $z = -0.3$ (top) and a zy plane at $x = 0$ (bottom) are shown on the left, and two isosurfaces of the convolution kernel are shown on the right.

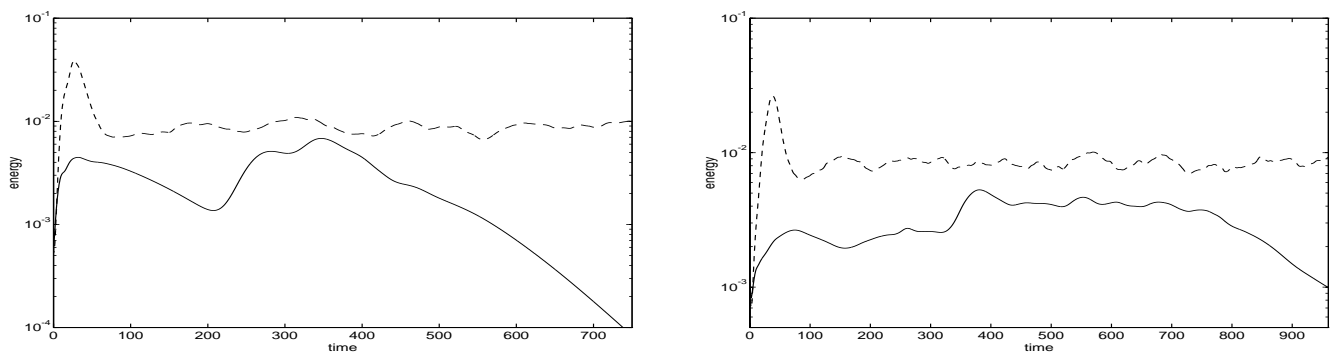

FIG. 4. Control of oblique waves (left) and an initially random flow perturbation (right). The magnitude of the initial flow perturbations in these simulations significantly exceed the thresholds reported by Reddy *et al.* (1998) that lead to transition to turbulence in an uncontrolled flow (by $225\times$ for the oblique waves and by $15\times$ for the random initial perturbation). Solid lines indicate the energy evolution in the controlled case, dashed lines indicate the energy evolution in the uncontrolled case. Both of the uncontrolled simulations result in transition to turbulence whereas both of the controlled systems relaminarize.

-
- ¹ BAMIEH, B., PAGANINI, F., & DAHLEH, M. 2000 Distributed Control of Spatially-Invariant Systems. *IEEE Trans. Auto. Control*, submitted.
- ² BEWLEY, T.R. 1999 Linear control and estimation of nonlinear chaotic convection: harnessing the butterfly effect. *Phys. Fluids* **11**, 1169-1186.
- ³ BEWLEY, T.R., & LIU, S. 1998 Optimal and robust control and estimation of linear paths to transition. *J. Fluid Mech.* **365**, 305-349.
- ⁴ BEWLEY, T.R., MOIN, P., & TEMAM, R. 2000 DNS-based predictive control of turbulence: an optimal benchmark for feedback algorithms. *J. Fluid Mech.*, submitted.
- ⁵ BERLIN, S., WIEGEL, M., & HENNINGSON, D.S. 1999 Numerical and experimental investigations of oblique boundary layer transition. *J. Fluid Mech.*, **393**, 23-57.
- ⁶ BUTLER, K.M., & FARRELL, B.F. 1992 Three-dimensional optimal perturbations in viscous shear flows. *Phys. Fluids A* **4**, 1637-1650.
- ⁷ CORTELEZZI, L., & SPEYER, J.L. 1998 Robust reduced-order controller of laminar boundary layer transitions. *Physical Review E* **58**, 1906-1910.
- ⁸ D'ANDREA, R., & DULLERUD, G.E. 2000 Distributed control of Spatially Interconnected Systems. *IEEE Trans. Automat. Contr.*, submitted.
- ⁹ FARRELL, B.F., & IOANNOU, P.J. 1993 Stochastic forcing of the linearized Navier-Stokes equation. *Phys. Fluids A* **5**, 2600-2609.
- ¹⁰ HUANG, W., & SLOAN, D.M. 1993 The pseudo-spectral method for solving differential eigenvalue problems. *J. Comput. Phys.* **111**, 399-409.
- ¹¹ REDDY, S.C., SCHMID, P.J., BAGGETT, J.S., & HENNINGSON, D.S. 1998 On stability of streamwise streaks and transition thresholds in plane channel flows. *J. Fluid Mech.* **365**, 269-303.
- ¹² SCHMID, P.J., & HENNINGSON, D.S. 2000 *Stability and transition in shear flows*. Springer (in press).
- ¹³ TREFETHEN, L.N., TREFETHEN, A.E., REDDY, S.C., & DRISCOLL, T.A. 1993 Hydrodynamic stability without eigenvalues *Science* **261**, 578-584.
- ¹⁴ WEIDEMAN, J.A.C., & REDDY S.C. 1999 A Matlab Differentiation Matrix Suite. *ACM Transactions of Mathematical Software*, to appear.