

Backlash Compensation with Filtered Prediction in Discrete Time Nonlinear Systems by Dynamic Inversion Using Neural Networks

J. Campos, F. L. Lewis, and R. Selmic.
Automation and Robotics Research Institute
The University of Texas at Arlington
7300 Jack Newell Blvd. S,
Ft. Worth, Texas 76118-7115
jcampos@mvista.com

Research Supported by: ARO Grant DAAD19-99-1-0137 and Texas ATP Grant 003656-027

Abstract

A dynamics inversion compensation scheme is designed for control of nonlinear discrete-time systems with input backlash. This paper extends the dynamic inversion technique to discrete-time systems by using a filtered prediction, and shows how to use a neural network (NN) for inverting the backlash nonlinearity in the feedforward path. The technique provides a general procedure for using NN to determine the dynamics preinverse of an invertible discrete time dynamical system. A discrete-time tuning algorithm is given for the NN weights so that the backlash compensation scheme guarantees bounded tracking and backlash errors, and also bounded parameter estimates. A rigorous proof of stability and performance is given and a simulation example verifies performance. Unlike standard discrete-time adaptive control techniques, no certainty equivalence (CE) or linear-in-parameters (LIP) assumptions are needed.

1 Introduction

Many physical components of control systems have nonsmooth nonlinear characteristics such as deadzone and backlash. These are particularly common in actuators, such as mechanical connections, hydraulic servovalves and electric servomotors. The difference between toothspace and tooth width in mechanical system is known as backlash and it is necessary to allow two gears mesh without jamming. Any amount of backlash greater than the minimum amount necessary to ensure satisfactory meshing of gears can result in instability in dynamics situations and position errors in gear trains. Backlash often severely limits the performance of feedback systems by causing delays, oscillations, and inaccuracy. In fact, there are many applications such as instrument differential gear trains and servomechanisms that require the complete elimination of backlash in order to function properly. Many mechanical solutions have been developed to overcome backlash, for example spring-loaded split gear assemblies and dual motor systems. These mechanical solutions can satisfactorily handle the backlash problem but they give rise to others problems like decreased accuracy and reduced bandwidth. They are also expensive, energy consuming and increase the overall weight of the system. A backlash compensation scheme not based on mechanical devices would be more convenient.

In most applications the backlash parameters are either poorly known or completely unknown, which represent a challenge for the control design engineer. Proportional-derivative (PD) controllers have been observed to result in limit cycles if the actuators have nonlinearities such as backlash or deadzones. To overcome the PD controller limitations, several techniques have been applied to compensate for the actuator nonlinearities. These techniques include adaptive control, fuzzy logic and neural networks. Recently, in seminal work rigorously derived adaptive

schemes have been given for actuator nonlinearity compensation [18][20]. Continuous time backlash compensation using adaptive control is addressed in [6][8][19]. For dynamic system in the Lagrangian form, continuous time deadzone compensation using neural networks is given in [16].

Many systems with actuator nonlinearities such as deadzone and backlash are modeled in discrete time. Moreover, for implementation as a digital controller, a discrete-time actuator nonlinearity compensator is needed. To address discrete-time deadzone compensation, an adaptive control approach has been proposed in the seminal work [18][21]. Also a fuzzy logic (FL) deadzone compensation discrete time scheme is proposed in [4]. Adaptive control approaches for backlash compensation in discrete time are presented in [5][18][20]. These all require a linear in the parameter assumption.

Dynamics inversion in continuous-time using NN is presented in [11][14], where a NN is used for cancellation of the system inversion error. A continuous time dynamic inversion approach using NN for backlash compensation is presented in [15]. A continuous time inverse dynamics approach using adaptive and robust control technique is presented in [17]. A preliminary approach using dynamic inversion for backlash compensation in discrete-time system is given in [3]. That work was incomplete in that the proof did not rigorously include the effects of a certain predictive filter needed to actually implement the technique. This paper repairs that problem.

Dynamic inversion is a form of backstepping. Backstepping was extended to discrete-time systems in [2][7][10][22][23]. The difficulty with applying those results to discrete-time dynamic inversion is that a future value of a certain ideal control input is needed. This paper shows how to confront that problem.

In this paper we provide the complete solution for extending dynamics inversion to discrete-time systems by using a filtered prediction approach for backlash compensation. The general case of nonsymmetric backlash is treated. A rigorous design procedure is given that results in a PD tracking loop with an adaptive NN in the feedforward loop for dynamic inversion of the backlash nonlinearity. The NN feedforward compensator is adapted in such a way as to estimate on-line the backlash inverse. Unlike standard discrete-time adaptive control techniques, no certainty equivalence (CE) assumption is needed since the tracking error and the estimation error, are weighted in the same Lyapunov function. Unlike [17][18], no linearity in the parameters is needed. The approach is similar to that in [9], but additional complexities arise due to the fact that the backlash compensator is in the feedforward loop.

2 Dynamics of an mn-th order MIMO system

Consider an mn-th order multi-input and multi-output discrete-time system given by

$$\begin{aligned} x_1(k+1) &= x_2(k) \\ &\vdots \\ x_{n-1}(k+1) &= x_n(k) \\ x_n(k+1) &= f(x(k)) + t(k) + d(k), \end{aligned} \quad (1)$$

where $x(k) = [x_1(k), x_2(k), \dots, x_n(k)]^T$ with $x_i(k) \in \mathfrak{R}^n$; $i = 1, 2, \dots, n$, $u(k) \in \mathfrak{R}^m$, and $d(k) \in \mathfrak{R}^m$ denotes a disturbance vector acting on the system at the instant k with $\|d(k)\| \leq d_M$ a known constant. The actuator output $t(k)$ is related to the control input $u(k)$ through the backlash nonlinearity. $t(k) = \text{Backlash}(u(k))$ as discussed in the next section. Given a desired trajectory $x_{nd}(k)$ and its delayed values, define the tracking error as

$$e_n(k) = x_n(k) - x_{nd}(k). \quad (2)$$

It is typical in robotics to define a so-called the filtered tracking error, as $r(k) \in \mathfrak{R}^m$, and given by

$$r(k) = e_n(k) + I_1 e_{n-1}(k) + \dots + I_{n-1} e_1(k), \quad (3)$$

where $e_{n-1}(k), \dots, e_1(k)$ are the delayed values of the error $e_n(k)$, and I_1, \dots, I_{n-1} are constant matrices selected so that $|z^{n-1} + I_1 z^{n-2} + \dots + I_{n-1}|$ is stable or Hurwitz (i.e., $e_n(k) \rightarrow 0$ exponentially as $r(k) \rightarrow 0$). Equation (3) can be further expressed as

$$r(k+1) = e_n(k+1) + I_1 e_{n-1}(k+1) + \dots + I_{n-1} e_1(k+1). \quad (4)$$

Using Eq. (1) in Eq. (4), the dynamics of the mn-th order MIMO system can be written in terms of the tracking error as

$$r(k+1) = f(x(k)) - x_{nd}(k+1) + I_1 e_{n-1}(k) + \dots + I_{n-1} e_1(k) + t(k) + d(k). \quad (5)$$

3 Backlash Nonlinearity and Backlash Inverse

The backlash nonlinearity is shown in Fig. 1, and the mathematical model for continuous time is given by [15][18]. For the discrete-time case, one has

$$t(k+1) = B(t(k), u(k), u(k+1)) = \begin{cases} m \cdot u(k+1), & \text{if } u(k+1) > 0 \text{ and } u(k) = m \cdot t(k) - m \cdot d_+ \\ m \cdot u(k+1), & \text{if } u(k+1) < 0 \text{ and } u(k) = m \cdot t(k) - m \cdot d_- \\ 0, & \text{otherwise} \end{cases} \quad (6)$$

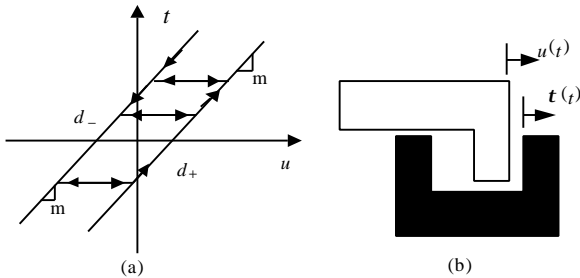

Fig. 1: (a) Backlash Model.
(b) Backlash in Mechanical connections.

It can be seen that backlash is a first-order velocity driven dynamic system, with inputs $u(k)$ and $u(k+1)$, and state $t(k)$. Backlash contains its own dynamics, therefore its compensation requires the design of a dynamic compensator [15].

Whenever the motion $u(k)$ changes its direction, the motion $t(k)$ is delayed from motion of $u(k)$. The objective of the backlash compensator is to make this delay as small as possible

(i.e., to make the throughput from $u(k)$ to $t(k)$ be the unity). The backlash precompensator needs to generate the inverse of the backlash nonlinearity. The backlash inverse function is shown in Fig. 2.

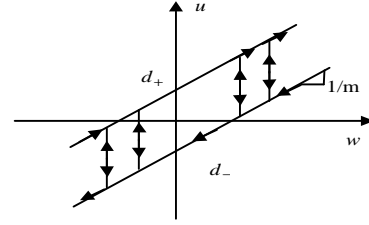

Fig. 2: Backlash Inverse

The dynamics of the NN backlash compensator is given by

$$u(k+1) = B_{inv}(u(k), w(k), w(k+1)), \quad (7)$$

The backlash inverse characteristic shown in the Fig. 2 can be decomposed into two functions [15]: a direct feedforward term plus an additional *modified backlash inverse* term as shown in Fig. 3. This decomposition allows design of a compensator that has a better structure than when a NN is used directly in the feedforward path.

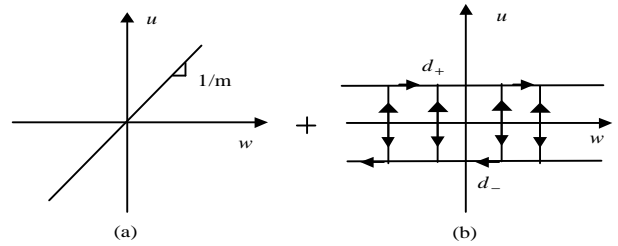

Fig. 3: Backlash inverse decomposition.

4 Discrete Time NN Backlash Compensator

The discrete time NN backlash compensator is designed using the backstepping technique. In this section we will show how to tune the NN weights on-line so that the tracking error is guaranteed small and all internal states are bounded. It is assumed that the actuator output $t(k)$ is measurable. Unlike [17][18], no linearity in the parameters assumption is needed.

4.1 Dynamics of Nonlinear System with Backlash

Equation (1) is in the companion form and represents a large class of multi-input multi-output (MIMO) nonlinear systems. The overall system dynamics consist of (1) and the backlash dynamics (6).

The following assumptions are needed and they are true in every practical situation and are standard in the existing literature.

Assumption 1 (Bounded disturbance): The unknown disturbance satisfies $\|d(k)\| \leq d_M$, with d_M a known positive constant.

Assumption 2 (Bounded estimation error): The nonlinear function is assumed to be unknown, but a fixed estimate $\hat{f}(x(k))$ is assumed known such that the functional estimation error, $\tilde{f}(x(k)) = f(x(k)) - \hat{f}(x(k))$, satisfies $\|\tilde{f}(x(k))\| \leq f_M(x(k))$, for some known bounding function $f_M(x(k))$.

Assumption 3 (Bounded desired trajectories): The desired trajectory is bounded in the sense, for instance that

$$\begin{bmatrix} x_{1d}(k) \\ x_{2d}(k) \\ \vdots \\ x_{nd}(k) \end{bmatrix} \leq X_d.$$

4.2 Backstepping Controller

A robust compensation scheme for unknown terms in $f(x(k))$ is provided by selecting the tracking controller

$$\begin{aligned} \mathbf{t}_{des}(k) = & K_v \cdot r(k) - \hat{f}(x(k)) + x_{nd}(k+1) - \mathbf{I}_1 \cdot e_{n-1}(k) + \\ & - \mathbf{I}_2 \cdot e_{n-2}(k) - \dots - \mathbf{I}_{n-1} \cdot e_1(k), \end{aligned} \quad (8)$$

with $\hat{f}(x(k))$ an estimate for the nonlinear terms $f(x(k))$. The feedback gain matrix $K_v > 0$ is often selected diagonal. The problem of finding $\hat{f}(x(k))$ is not the main concern of this paper, so it is considered to be available. This function $f(x(k))$ can be estimated using adaptive control techniques [12] or neural network controllers [13].

Using (8) as a control input, the system dynamics in (5) can be rewritten as

$$r(k+1) = K_v \cdot r(k) + \tilde{f}(x(k)) + d(k). \quad (9)$$

The next theorem is the first step in the backstepping design; and it shows that the desired control law (8) will keep the filtered tracking error small if there is no backlash.

Theorem 1 (Control law for outer tracking loop).

Considered the system given by equation (1). Assume that Assumptions 1 and 2 hold, and let the control action be provided by (8) with $0 < K_v < 1$ being a design parameter.

Then the filtered tracking error $r(k)$ is UUB.

Proof.

Let us consider the following Lyapunov function candidate

$$L_1(k) = r(k)^T r(k). \quad (10)$$

The first difference is

$$\begin{aligned} \Delta L_1(k) = & r(k+1)^T r(k+1) - r(k)^T r(k) = \\ = & \left(K_v r(k) + \tilde{f}(x(k)) + d(k) \right)^T \left(K_v r(k) + \tilde{f}(x(k)) + d(k) \right) - r(k)^T r(k) \end{aligned} \quad (11)$$

$\Delta L_1(k)$ is negative if the following is satisfied

$$\begin{aligned} \left\| K_v r(k) + \tilde{f}(x(k)) + d(k) \right\| & \leq K_{v\max} \|r(k)\| + f_M + d_M < \|r(k)\| \\ \Rightarrow (1 - K_{v\max}) \|r(k)\| & > f_M + d_M, \end{aligned}$$

which is true as long as

$$\|r(k)\| > \frac{f_M + d_M}{1 - K_{v\max}}. \quad (12)$$

Therefore, $\Delta L_1(k)$ is negative outside a compact set. According to standard Lyapunov theory extension [12], this demonstrates the UUB of $r(k)$.

4.3 NN Backlash Compensation using Dynamic Inversion

Theorem 1 gives the control law that guarantees stability in term of the filtered tracking error assuming that no nonlinearity besides the system nonlinear function plus some bounded external disturbances are present. In the presence of unknown backlash nonlinearity, the desired and actual value of the control signal $\mathbf{t}(k)$ will be different. A dynamics inversion technique by neural networks is used for compensation of the inversion error [11][14][15]. This is form of backstepping.

The actuator output given by (8) is the desired signal. The complete error system dynamics can be found defining the error

$$\tilde{\mathbf{t}}(k) = \mathbf{t}_{des}(k) - \mathbf{t}(k). \quad (13)$$

Using the desired control input (8), under the presence of unknown backlash the system dynamics (5) can be rewritten as

$$r(k+1) = K_v \cdot r(k) + \tilde{f}(x(k)) + d(k) - \tilde{\mathbf{t}}(k). \quad (14)$$

Evaluating (13) at the following time interval

$$\begin{aligned} \tilde{\mathbf{t}}(k+1) = & \mathbf{t}_{des}(k+1) - \mathbf{t}(k+1) = \mathbf{t}_{des}(k+1) + \\ & - B(\mathbf{t}(k), u(k), u(k+1)) \end{aligned} \quad (15)$$

which together with (14) represents the complete system error dynamics.

The dynamics of the backlash nonlinearity can be written as [15]

$$\mathbf{t}(k+1) = \mathbf{j}(k), \quad (16)$$

$$\mathbf{j}(k) = B(\mathbf{t}(k), u(k), u(k+1)), \quad (17)$$

where $\mathbf{j}(k)$ is a pseudo-control input [11][14][15]. In the case of known backlash, the ideal backlash inverse is given by

$$u(k+1) = B^{-1}(u(k), \mathbf{t}(k), \mathbf{j}(k)). \quad (18)$$

Since the backlash and therefore its inverse are not known, one can only approximate the backlash inverse as

$$\hat{u}(k+1) = \hat{B}^{-1}(\hat{u}(k), \mathbf{t}(k), \mathbf{j}(k)). \quad (19)$$

The backlash dynamics can now be written as

$$\begin{aligned} \mathbf{t}(k+1) = & B(\mathbf{t}(k), \hat{u}(k), \hat{u}(k+1)) \\ = & \hat{B}(\mathbf{t}(k), \hat{u}(k), \hat{u}(k+1)) + \tilde{B}(\mathbf{t}(k), \hat{u}(k), \hat{u}(k+1)), \\ = & \mathbf{j}(k) + \tilde{B}(\mathbf{t}(k), \hat{u}(k), \hat{u}(k+1)) \end{aligned} \quad (20)$$

where $\mathbf{j}(k) = \hat{B}(\mathbf{t}(k), \hat{u}(k), \hat{u}(k+1))$ and therefore its inverse is given by $\hat{u}(k+1) = \hat{B}^{-1}(\mathbf{t}(k), \hat{u}(k), \mathbf{j}(k))$. The unknown function $\tilde{B}(\mathbf{t}(k), \hat{u}(k), \hat{u}(k+1))$, which represents the backlash inversion error, will be approximated using a neural network.

In order to design a stable closed-loop system with backlash compensation, one selects a nominal backlash inverse $\hat{u}(k+1) = \mathbf{j}(k)$ and pseudo-control input as

$$\mathbf{j}(k) = -K_b \tilde{\mathbf{t}}(k) + \mathbf{t}_{filt}(k) + \hat{W}(k)^T \mathbf{s}(V^T x_{nn}(k)), \quad (21)$$

where $K_b > 0$ is a design parameter, and \mathbf{t}_{filt} is a discrete-time filtered version of \mathbf{t}_{des} . \mathbf{t}_{filt} is a filtered prediction that approximates $\mathbf{t}_{des}(k+1)$, and is obtained using the discrete-time filter $az/(z+a)$ as shown in Fig. 4. This is the equivalent of using a filtered derivative instead of a pure derivative in continuous-time dynamics inversion, which is standard in industrial control systems. The filter dynamics shown in Fig. 4 can be written as

$$\mathbf{t}_{filt}(k) = -\frac{\mathbf{t}_{filt}(k+1)}{a} + \mathbf{t}_{des}(k+1), \quad (22)$$

where a is a design parameter. It can be seen that when the filter parameter a is large enough we have $\mathbf{t}_{filt}(k) \approx \mathbf{t}_{des}(k+1)$. The

mismatch term $-\frac{\mathbf{t}_{filt}(k+1)}{a}$ can be approximated along with the backlash inversion error using the NN.

Based on the NN approximation property, the backlash inversion plus the filter error dynamics can be represented as

$$\tilde{B}(\mathbf{t}(k), \hat{u}(k), \hat{u}(k+1)) + \frac{\mathbf{t}_{filt}(k+1)}{a} = W(k)^T \mathbf{s}(V^T x_{nn}(k)) + \mathbf{e}(k), \quad (23)$$

where the NN input vector is chosen to be $x_{nn}(k) = \begin{bmatrix} 1 & r(k)^T & x_d(k)^T & \tilde{\mathbf{t}}(k)^T & \mathbf{t}(k)^T \end{bmatrix}^T$, and $\mathbf{e}(k)$ represents the NN approximation error. It can be seen that the first layer of weights is not time dependant since it is selected randomly at initial time to provide a basis [1] and then it is kept constant through the tuning process.

Define the NN weight estimation error as

$$\tilde{W}(k) = W(k) - \hat{W}(k), \quad (24)$$

where $\hat{W}(k)$ is the estimate of the ideal NN weights $W(k)$.

Using the proposed controller shown in Fig. 4, the error dynamics can be written as

$$\begin{aligned}
\tilde{\mathbf{f}}(k+1) &= \mathbf{t}_{des}(k+1) - \hat{\mathbf{f}}(k) + \tilde{\mathbf{B}}(\mathbf{t}(k), \hat{\mathbf{u}}(k), \hat{\mathbf{u}}(k+1)) = \\
&= K_b \tilde{\mathbf{f}}(k) + \frac{\mathbf{t}_{filt}(k+1)}{a} - \tilde{\mathbf{W}}(k)^T \mathbf{s}(V^T x_{nn}(k)) + \tilde{\mathbf{B}}(\mathbf{t}(k), \hat{\mathbf{u}}(k), \hat{\mathbf{u}}(k+1)) = , \\
&= K_b \tilde{\mathbf{f}}(k) - \tilde{\mathbf{W}}(k)^T \mathbf{s}(V^T x_{nn}(k)) + \mathbf{W}(k)^T \mathbf{s}(V^T x_{nn}(k)) + \mathbf{e}(k)
\end{aligned} \tag{25}$$

Using (24),

$$\tilde{\mathbf{f}}(k+1) = K_b \tilde{\mathbf{f}}(k) + \tilde{\mathbf{W}}(k)^T \mathbf{s}(V^T x_{nn}(k)) + \mathbf{e}(k). \tag{26}$$

The next theorem is our main result and it shows how to tune the neural network weights so the tracking error $r(k)$ and backlash estimation error $\tilde{\mathbf{f}}(k)$ achieve small values while the NN weights estimation errors $\tilde{\mathbf{W}}(k)$ are bounded.

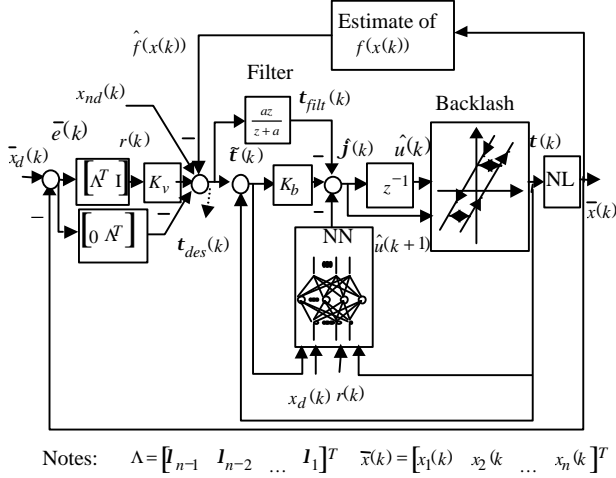

Fig. 4: Discrete Time NN Backlash Compensator.

Theorem 2 (Control law for backstepping loop).

Consider the system given by (1). Provided that assumptions 1, 2, and 3 hold, let the control action $\hat{\mathbf{f}}(k)$ be provided by (21) with $K_b > 0$ being a design parameter.

Let $u(k+1) = \hat{\mathbf{f}}(k)$, and the estimated NN weights be provided by the NN tuning law

$$\begin{aligned}
\hat{\mathbf{W}}(k+1) &= \hat{\mathbf{W}}(k) + \mathbf{a}\mathbf{s}(k)r(k+1)^T + \mathbf{a}\mathbf{s}(k)\tilde{\mathbf{f}}(k+1)^T + \\
&- \Gamma \left\| I - \mathbf{a}\mathbf{s}(k)\mathbf{s}(k)^T \right\| \hat{\mathbf{W}}(k),
\end{aligned} \tag{27}$$

where $\mathbf{a} > 0$ is a constant learning rate parameter or adaptation gain, $\Gamma > 0$ is a design parameter, and for simplicity purposes $\mathbf{s}(V^T x_{nn}(k))$ is represented as $\mathbf{s}(k)$. Then, the filtered tracking error $r(k)$, the backlash estimation error $\tilde{\mathbf{f}}(k)$, and the NN weight estimation error $\tilde{\mathbf{W}}(k)$ are UUB, provided the following conditions hold:

$$1) 0 < \mathbf{a}\mathbf{s}(k)^T \mathbf{s}(k) < 1/2, \tag{28}$$

$$2) 0 < \Gamma < 1, \tag{29}$$

$$3) 0 < K_v < I \text{ and } K_{v\max} < \frac{1}{\sqrt{h+2}}, \tag{30}$$

where

$$\mathbf{b} = K_v^{-1}(2I - K_v) + (I - \mathbf{a}\mathbf{s}(k)^T \mathbf{s}(k))K_v^{-T} K_v^{-1} > 0. \tag{31}$$

$$\begin{aligned}
\mathbf{r} &= (I - \mathbf{a}\mathbf{s}(k)^T \mathbf{s}(k))I + \\
&- \mathbf{b}^{-1} \left(\mathbf{a}\mathbf{s}(k)^T \mathbf{s}(k) + \Gamma \left\| I - \mathbf{a}\mathbf{s}(k)\mathbf{s}(k)^T \right\| \right)^2 > 0.
\end{aligned} \tag{32}$$

$$\mathbf{h} = (I + \mathbf{a}\mathbf{s}(k)^T \mathbf{s}(k))I + + \tag{33}$$

$$\mathbf{r}^{-1} \left(\mathbf{a}\mathbf{s}(k)^T \mathbf{s}(k) + \Gamma \left\| I - \mathbf{a}\mathbf{s}(k)\mathbf{s}(k)^T \right\| \right)^2 > 0.$$

Theorem Proof: See Appendix B.

Note that condition (31) is true because of (28) and (30). Note also that (33) is satisfied because of conditions (28) and (32). Proof for condition (32) is given in Appendix A.

Remarks:

It is important to note that in this theorem there is no certainty equivalence (CE) assumption, in contrast to standard work in discrete-time adaptive control. In the latter, a parameter identifier is first selected and the parameter estimation errors are assumed small. In the tracking proof, it is assumed that the parameter estimates are exact (the CE assumption), and a Lyapunov function is selected that weights only the tracking error to demonstrate close-loop stability and tracking performance. This approach is used for instance in [21]. By contrast, in our proof, the Lyapunov function in the Appendix B is of the form (B.4) which weights the tracking error $r(k)$, backlash estimation error $\tilde{\mathbf{f}}(k)$ and the NN weight estimation error $\tilde{\mathbf{W}}(k)$. This requires an exceedingly complex proof, but obviates the need for any sort of CE assumption. It also allows the parameter-tuning algorithm to be derived during the proof process, not selected a priori in an ad hoc manner. This is akin to the proof of [9], but additional complexities arise due to the fact that the backlash compensator NN system is in the feedforward loop.

The third term in (27) is a discrete-time version of Narendra's e-mod, which is required to provide robustness due to the coupling in the proof between tracking error, backlash error terms and weight estimation error terms in the Lyapunov function. This is called a 'forgetting term' in NN weight-tuning algorithms. These are required in that context to prevent parameter overtraining.

5 Simulation Results

In this section, the discrete-time NN backlash compensator is simulated on a digital computer. It is found to be very efficient at canceling the deleterious effects of actuator backlash.

5.1 Simulation

We simulate the response for the known plant with input backlash, both with and without the NN compensator. Consider the following nonlinear plant

$$\begin{aligned}
x_1(k+1) &= x_2(k), \\
x_2(k+1) &= -\frac{3}{16} \left[\frac{x_1(k)}{1+x_2^2(k)} \right] + x_2(k) + u(k).
\end{aligned}$$

The deadband widths for the backlash nonlinearity were selected as $d_+ = d_- = 0.2$ and the slope as $m = 0.5$.

5.1.1 Trajectory Tracking

In this subsection we simulate the trajectory tracking performance of the system for sinusoidal reference signals. The reference signal used was selected to be

$$x_d(k) = \sin(w \cdot t_k + \mathbf{f}), \quad w = 0.5, \mathbf{f} = \mathbf{P}/2.$$

The sampling period was selected as $T = 0.001$ s.

Fig. 5 shows the system response without backlash using a standard PD controller. The PD controller does a good job on the tracking which is achieved at about 2 seconds. Fig. 6 shows the system response with input backlash. The system backlash destroys the tracking and the PD controller by itself is not capable of compensating for that. Fig. 7 shows the same situation but using the proposed discrete-time NN backlash compensator. The backlash compensator takes care of the system backlash and the tracking is achieved in less than 0.5 seconds.

6 Conclusion

A discrete-time dynamic inversion compensation with a filtered prediction has been proposed for backlash compensation in nonlinear systems. The compensator uses the dynamic inversion technique with neural networks (NN) for inverting the backlash nonlinearity in the feedforward path. It was shown how to tune the NN weights in discrete-time so that the unknown backlash parameters are learned on-line, resulting in a discrete-time adaptive backlash compensator. Using discrete-time nonlinear stability techniques, the tuning algorithm was rigorously shown to guarantee small tracking errors as well as bounded parameter estimates. Since the tracking error, backlash error and the parameter estimation error are weighted in the same Lyapunov function, no certainty equivalence assumption is needed.

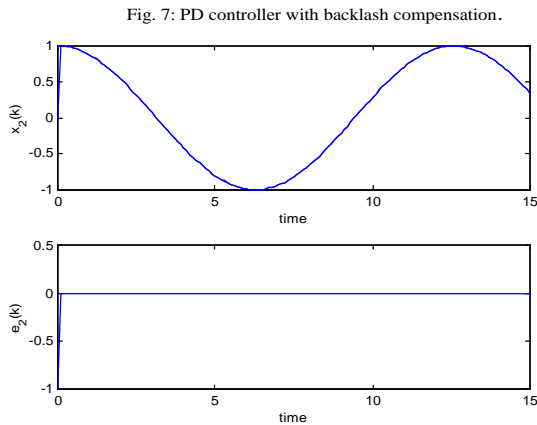
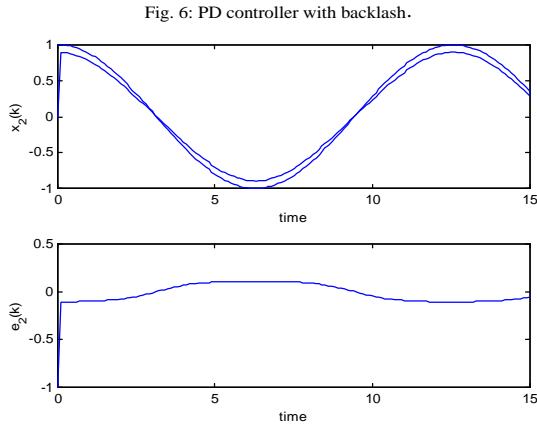
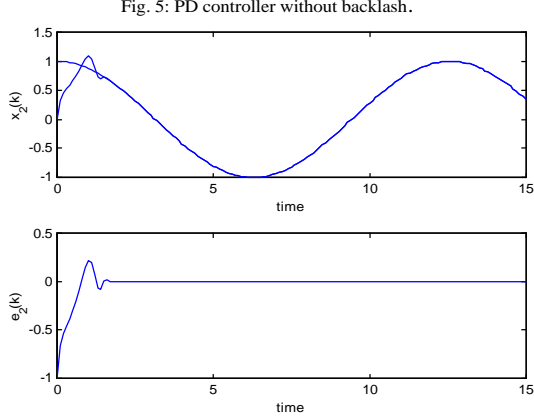

Appendix A: Proof of Condition (32).

Note: For simplicity purposes, from now on we will omit the k sub-index. So, every variable is supposed to have a k sub-index unless specified otherwise. This statement is valid only for the proofs shown in the appendices.

Because of condition (28), we have that $(1 - \mathbf{a}\mathbf{s}^T\mathbf{s})I > \frac{1}{2}I$. Also using (28), (29) we have that

$$\left(\mathbf{a}\mathbf{s}^T\mathbf{s} + \Gamma\|I - \mathbf{a}\mathbf{s}\mathbf{s}^T\|\right)^2 < \frac{1}{4}I$$

Using (30) we have that $\mathbf{b} > I$ (i.e. $\mathbf{b}^{-1} < I$). Then we can conclude that $\mathbf{b}^{-1}\left(\mathbf{a}\mathbf{s}^T\mathbf{s} + \Gamma\|I - \mathbf{a}\mathbf{s}\mathbf{s}^T\|\right)^2 < \frac{1}{4}I$. Finally, using this last result we can show that

$$r = (1 - \mathbf{a}\mathbf{s}^T\mathbf{s})I - \mathbf{b}^{-1}\left(\mathbf{a}\mathbf{s}^T\mathbf{s} + \Gamma\|I - \mathbf{a}\mathbf{s}\mathbf{s}^T\|\right)^2 > \frac{1}{4}I > 0.$$

Appendix B: Proof of Theorem 2.

For simplicity purposes let us rewrite the system dynamics as

$$r_{k+1} = K_v \cdot r + D - \tilde{\mathbf{f}}. \quad (\text{B.1})$$

where $D = \tilde{f} + d$. And let us rewrite the backlash dynamics as

$$\tilde{\mathbf{f}}_{k+1} = K_b\tilde{\mathbf{f}} + \tilde{W}^T\mathbf{s}(v^T x_{nn}) + \mathbf{e}. \quad (\text{B.2})$$

Using the following Lyapunov function candidate

$$L = \begin{bmatrix} r^T & \tilde{\mathbf{f}}^T \end{bmatrix} \begin{bmatrix} 2 & 1 \\ 1 & 1 \end{bmatrix} \begin{bmatrix} r \\ \tilde{\mathbf{f}} \end{bmatrix} + \frac{1}{\mathbf{a}}\text{tr}(\tilde{W}^T\tilde{W}) > 0. \quad (\text{B.3})$$

This can be rewritten as

$$L = 2r^T r + 2r^T \tilde{\mathbf{f}} + \tilde{\mathbf{f}}^T \tilde{\mathbf{f}} + \frac{1}{\mathbf{a}}\text{tr}(\tilde{W}^T\tilde{W}) = L_1 + L_2 + L_3 + L_4. \quad (\text{B.4})$$

Taking the first difference

$$\begin{aligned} \Delta L_1 &= 2r_{k+1}^T r_{k+1} - 2r^T r = \\ &= -2r^T [I - K_v^T K_v] r + 4r^T K_v^T D - 4r^T K_v^T \tilde{\mathbf{f}} + 2D^T D - 4D^T \tilde{\mathbf{f}} + 2\tilde{\mathbf{f}}^T \tilde{\mathbf{f}}. \\ \Delta L_2 &= 2r_{k+1}^T \tilde{\mathbf{f}}_{k+1} - 2r^T \tilde{\mathbf{f}} = 2r^T K_v^T K_b \tilde{\mathbf{f}} + 2r^T K_v^T \tilde{W}^T \mathbf{s} + 2r^T K_v^T \mathbf{e} + \\ &+ 2D^T K_b \tilde{\mathbf{f}} + 2D^T \tilde{W}^T \mathbf{s} + 2D^T \mathbf{e} - 2\tilde{\mathbf{f}}^T K_b^T K_b \tilde{\mathbf{f}} - 2\tilde{\mathbf{f}}^T \tilde{W}^T \mathbf{s} - 2\tilde{\mathbf{f}}^T \mathbf{e} + \\ &- 2r^T \tilde{\mathbf{f}}. \\ \Delta L_3 &= \tilde{\mathbf{f}}_{k+1}^T \tilde{\mathbf{f}}_{k+1} - \tilde{\mathbf{f}}^T \tilde{\mathbf{f}} = \tilde{\mathbf{f}}^T K_b^T K_b \tilde{\mathbf{f}} + 2\tilde{\mathbf{f}}^T K_b^T \tilde{W}^T \mathbf{s} + 2\tilde{\mathbf{f}}^T K_b^T \mathbf{e} + \\ &+ \mathbf{s}^T \tilde{W} \tilde{W}^T \mathbf{s} + 2\mathbf{e}^T \tilde{W}^T \mathbf{s} + \mathbf{e}^T \mathbf{e} - \tilde{\mathbf{f}}^T \tilde{\mathbf{f}}. \\ \Delta L_4 &= \frac{1}{\mathbf{a}}\text{tr}(\tilde{W}_{k+1}^T \tilde{W}_{k+1} - \tilde{W}^T \tilde{W}) = \\ &= \frac{1}{\mathbf{a}}\text{tr}(\hat{W}_{k+1}^T \hat{W}_{k+1} + W^T W - 2W^T \hat{W}_{k+1} - \tilde{W}^T \tilde{W}). \end{aligned}$$

Pick $K_b = (I + K_v^{-1})^T = I + K_a$ and define the term $\mathbf{b} = 2K_a + (1 - \mathbf{a}\mathbf{s}^T\mathbf{s})K_a^T K_a - I > 0$ (condition (31)) which is true as long as $K_v^{-1} < I$ (condition (30)). It can be seen that $\mathbf{b} > I$ and \mathbf{b} is a diagonal matrix since K_a is diagonal.

Combining all terms and select the tuning law given by (B.5) and using equations (B.1) and (B.2)

$$\hat{W}_{k+1} = \hat{W} + \mathbf{a}\mathbf{s} \cdot r_{k+1}^T + \mathbf{a}\mathbf{s} \cdot \tilde{\mathbf{f}}_{k+1}^T - \Gamma\|I - \mathbf{a}\mathbf{s}\mathbf{s}^T\|\hat{W}. \quad (\text{B.5})$$

$$\begin{aligned} \Delta L &= -r^T [2I - (2 + \mathbf{a}\mathbf{s}^T\mathbf{s})K_v^T K_v] r + 2(2 + \mathbf{a}\mathbf{s}^T\mathbf{s})r^T K_v^T D + \\ &+ (2 + \mathbf{a}\mathbf{s}^T\mathbf{s})D^T D + 2(1 + \mathbf{a}\mathbf{s}^T\mathbf{s})r^T K_v^T \mathbf{e} + (1 + \mathbf{a}\mathbf{s}^T\mathbf{s})\mathbf{e}^T \mathbf{e} + \\ &+ 2(1 + \mathbf{a}\mathbf{s}^T\mathbf{s})\mathbf{e}^T D - (I + \mathbf{b})\tilde{\mathbf{f}}^T \tilde{\mathbf{f}} - 2r^T K_v^T \tilde{\mathbf{f}} + 2\mathbf{a}\mathbf{s}^T \mathbf{s} r^T \tilde{\mathbf{f}} + \\ &+ 2(1 + \mathbf{a}\mathbf{s}^T\mathbf{s})D^T K_a \tilde{\mathbf{f}} - 2D^T \tilde{\mathbf{f}} + 2\mathbf{a}\tilde{\mathbf{f}}^T K_a^T \mathbf{s}^T \tilde{W}^T \mathbf{s} + \\ &+ 2(1 + \mathbf{a}\mathbf{s}^T\mathbf{s})\tilde{\mathbf{f}}^T K_a - 2\Gamma\|I - \mathbf{a} \cdot \mathbf{s} \cdot \mathbf{s}^T\|\tilde{\mathbf{f}}^T K_a^T W^T \mathbf{s} + \\ &+ 2\Gamma\|I - \mathbf{a} \cdot \mathbf{s} \cdot \mathbf{s}^T\|\tilde{\mathbf{f}}^T K_a^T \tilde{W}^T \mathbf{s} + 2\mathbf{a}\mathbf{s}^T \mathbf{s} r^T K_v^T \tilde{W}^T \mathbf{s} + \\ &- (1 - \mathbf{a}\mathbf{s}^T\mathbf{s})\mathbf{s}^T \tilde{W} \tilde{W}^T \mathbf{s} + 2\mathbf{a}\mathbf{s}^T \mathbf{s} \mathbf{e}^T \tilde{W}^T \mathbf{s} + 2\mathbf{a}\mathbf{s}^T \mathbf{s} r^T K_v^T \tilde{W}^T \mathbf{s} + \end{aligned}$$

$$\begin{aligned}
& - (1 - \mathbf{a}^T \mathbf{s}) \mathbf{s}^T \tilde{\mathbf{W}} \tilde{\mathbf{W}}^T \mathbf{s} + 2 \mathbf{a}^T \mathbf{s} \mathbf{e}^T \tilde{\mathbf{W}}^T \mathbf{s} + 2 \mathbf{a}^T \tilde{\mathbf{W}} \mathbf{s}^T \mathbf{D} + \\
& + 2\Gamma \left\| I - \mathbf{a} \cdot \mathbf{s} \cdot \mathbf{s}^T \right\| D^T \tilde{\mathbf{W}}^T \mathbf{s} + 2\Gamma \left\| I - \mathbf{a} \cdot \mathbf{s} \cdot \mathbf{s}^T \right\| r^T K_v^T \tilde{\mathbf{W}}^T \mathbf{s} + \\
& - 2\Gamma \left\| I - \mathbf{a} \cdot \mathbf{s} \cdot \mathbf{s}^T \right\| r^T K_v^T \tilde{\mathbf{W}}^T \mathbf{s} - 2\Gamma \left\| I - \mathbf{a} \cdot \mathbf{s} \cdot \mathbf{s}^T \right\| D^T \tilde{\mathbf{W}}^T \mathbf{s} + \\
& + 2\Gamma \left\| I - \mathbf{a} \cdot \mathbf{s} \cdot \mathbf{s}^T \right\| \mathbf{e}^T \tilde{\mathbf{W}}^T \mathbf{s} - 2\Gamma \left\| I - \mathbf{a} \cdot \mathbf{s} \cdot \mathbf{s}^T \right\| \mathbf{e}^T \tilde{\mathbf{W}}^T \mathbf{s} + \\
& - 2\Gamma \left\| I - \mathbf{a} \cdot \mathbf{s} \cdot \mathbf{s}^T \right\| \mathbf{s}^T \tilde{\mathbf{W}} \tilde{\mathbf{W}}^T \mathbf{s} + \frac{1}{a} \text{tr} \left\{ -2\Gamma \left\| I - \mathbf{a} \cdot \mathbf{s} \cdot \mathbf{s}^T \right\| \hat{\mathbf{W}}^T \hat{\mathbf{W}} + \right. \\
& \left. + 2W^T \Gamma \left\| I - \mathbf{a} \cdot \mathbf{s} \cdot \mathbf{s}^T \right\| \hat{\mathbf{W}} + \Gamma^2 \left\| I - \mathbf{a} \cdot \mathbf{s} \cdot \mathbf{s}^T \right\|^2 \hat{\mathbf{W}}^T \hat{\mathbf{W}} \right\}
\end{aligned}$$

Completing squares for $K_a \tilde{\mathbf{f}}, \tilde{\mathbf{f}}$ and $\tilde{\mathbf{W}}^T \mathbf{s}$. Define

$$\mathbf{r} = (1 - \mathbf{a}^T \mathbf{s}) I - \mathbf{b}^{-1} \left(\mathbf{a}^T \mathbf{s} + \Gamma \left\| I - \mathbf{a} \mathbf{s} \mathbf{s}^T \right\| \right)^2 > 0 \quad (\text{condition 32})$$

and then simplifying

$$\begin{aligned}
\Delta L = & -r^T [2I - (3 + \mathbf{a}^T \mathbf{s}) K_v^T K_v - (\mathbf{a}^T \mathbf{s})^2 + 2 \mathbf{a}^T \mathbf{s} K_v] r + \\
& + 2(1 + \mathbf{a}^T \mathbf{s}) r^T K_v^T (D + \mathbf{e}) + 4r^T K_v^T D + 2D^T D + \\
& - \left\{ K_a \tilde{\mathbf{f}} - \mathbf{b}^{-1} (1 + \mathbf{a}^T \mathbf{s}) (D + \mathbf{e}) + \right. \\
& \left. - \left(\mathbf{a}^T \mathbf{s} + \Gamma \left\| I - \mathbf{a} \mathbf{s} \mathbf{s}^T \right\| \right) \tilde{\mathbf{W}}^T \mathbf{s} + \Gamma \left\| I - \mathbf{a} \mathbf{s} \mathbf{s}^T \right\| \mathbf{W}^T \mathbf{s} \right\}^T \cdot \mathbf{b} \cdot \\
& \left\{ K_a \tilde{\mathbf{f}} - \mathbf{b}^{-1} (1 + \mathbf{a}^T \mathbf{s}) (D + \mathbf{e}) + \right. \\
& \left. - \left(\mathbf{a}^T \mathbf{s} + \Gamma \left\| I - \mathbf{a} \mathbf{s} \mathbf{s}^T \right\| \right) \tilde{\mathbf{W}}^T \mathbf{s} + \Gamma \left\| I - \mathbf{a} \mathbf{s} \mathbf{s}^T \right\| \mathbf{W}^T \mathbf{s} \right\}^T + \\
& - \left[\tilde{\mathbf{f}} - \mathbf{a}^T \mathbf{s} r + D + K_v r \right]^T \left[\tilde{\mathbf{f}} - \mathbf{a}^T \mathbf{s} r + D + K_v r \right] - 2 \mathbf{a}^T \mathbf{s} r^T D + \\
& + (1 + \mathbf{a}^T \mathbf{s}) \left(1 + \frac{1 + \mathbf{a}^T \mathbf{s}}{\mathbf{b}} \right) (D + \mathbf{e})^T (D + \mathbf{e}) + \\
& - \left\{ \tilde{\mathbf{W}}^T \mathbf{s} - \mathbf{r}^{-1} \left(\mathbf{a}^T \mathbf{s} + \Gamma \left\| I - \mathbf{a} \mathbf{s} \mathbf{s}^T \right\| \right) \right\}^T \cdot \\
& \left[K_v r + (1 + \mathbf{b}^{-1} (1 + \mathbf{a}^T \mathbf{s})) (D + \mathbf{e}) - \mathbf{b}^{-1} \Gamma \left\| I - \mathbf{a} \mathbf{s} \mathbf{s}^T \right\| \mathbf{W}^T \mathbf{s} \right]^T \cdot \mathbf{r} \\
& \left\{ \tilde{\mathbf{W}}^T \mathbf{s} - \mathbf{r}^{-1} \left(\mathbf{a}^T \mathbf{s} + \Gamma \left\| I - \mathbf{a} \mathbf{s} \mathbf{s}^T \right\| \right) \right\}^T \cdot \\
& \left[K_v r + (1 + \mathbf{b}^{-1} (1 + \mathbf{a}^T \mathbf{s})) (D + \mathbf{e}) - \mathbf{b}^{-1} \Gamma \left\| I - \mathbf{a} \mathbf{s} \mathbf{s}^T \right\| \mathbf{W}^T \mathbf{s} \right]^T + \\
& + \mathbf{r}^{-1} \left(\mathbf{a}^T \mathbf{s} + \Gamma \left\| I - \mathbf{a} \mathbf{s} \mathbf{s}^T \right\| \right)^2 \cdot \\
& \left[K_v r + (1 + \mathbf{b}^{-1} (1 + \mathbf{a}^T \mathbf{s})) (D + \mathbf{e}) - \mathbf{b}^{-1} \Gamma \left\| I - \mathbf{a} \mathbf{s} \mathbf{s}^T \right\| \mathbf{W}^T \mathbf{s} \right]^T \cdot \\
& \left[K_v r + (1 + \mathbf{b}^{-1} (1 + \mathbf{a}^T \mathbf{s})) (D + \mathbf{e}) - \mathbf{b}^{-1} \Gamma \left\| I - \mathbf{a} \mathbf{s} \mathbf{s}^T \right\| \mathbf{W}^T \mathbf{s} \right]^T + \\
& + \mathbf{b}^{-1} \Gamma^2 \left\| I - \mathbf{a} \mathbf{s} \mathbf{s}^T \right\|^2 \mathbf{s}^T \tilde{\mathbf{W}} \tilde{\mathbf{W}}^T \mathbf{s} + \\
& - 2 \mathbf{b}^{-1} (1 + \mathbf{a}^T \mathbf{s}) \Gamma \left\| I - \mathbf{a} \mathbf{s} \mathbf{s}^T \right\| (D + \mathbf{e})^T \mathbf{W}^T \mathbf{s} + \\
& - 2\Gamma \left\| I - \mathbf{a} \cdot \mathbf{s} \cdot \mathbf{s}^T \right\| r^T K_v^T \tilde{\mathbf{W}}^T \mathbf{s} - 2\Gamma \left\| I - \mathbf{a} \cdot \mathbf{s} \cdot \mathbf{s}^T \right\| (D + \mathbf{e})^T \mathbf{W}^T \mathbf{s} + \\
& - 2\Gamma \left\| I - \mathbf{a} \cdot \mathbf{s} \cdot \mathbf{s}^T \right\| \mathbf{s}^T \tilde{\mathbf{W}} \tilde{\mathbf{W}}^T \mathbf{s} + \frac{1}{a} \text{tr} \left\{ -2\Gamma \left\| I - \mathbf{a} \cdot \mathbf{s} \cdot \mathbf{s}^T \right\| \hat{\mathbf{W}}^T \hat{\mathbf{W}} + \right. \\
& \left. + 2W^T \Gamma \left\| I - \mathbf{a} \cdot \mathbf{s} \cdot \mathbf{s}^T \right\| \hat{\mathbf{W}} + \Gamma^2 \left\| I - \mathbf{a} \cdot \mathbf{s} \cdot \mathbf{s}^T \right\|^2 \hat{\mathbf{W}}^T \hat{\mathbf{W}} \right\}.
\end{aligned}$$

Putting the term $-2\Gamma \left\| I - \mathbf{a} \cdot \mathbf{s} \cdot \mathbf{s}^T \right\| \mathbf{s}^T \tilde{\mathbf{W}} \tilde{\mathbf{W}}^T \mathbf{s}$ back on the trace term and bounding the trace term.

$$\begin{aligned}
& \frac{1}{a} \text{tr} \left\{ -2a\Gamma \left\| I - \mathbf{a} \mathbf{s} \mathbf{s}^T \right\| \tilde{\mathbf{W}}^T \mathbf{s} \mathbf{s}^T \hat{\mathbf{W}} + 2\Gamma \left\| I - \mathbf{a} \mathbf{s} \mathbf{s}^T \right\| \tilde{\mathbf{W}}^T \hat{\mathbf{W}} + \right. \\
& \left. + \left\| I - \mathbf{a} \mathbf{s} \mathbf{s}^T \right\|^2 \hat{\mathbf{W}}^T \Gamma^T \hat{\mathbf{W}} \right\} < - \frac{\left\| I - \mathbf{a} \mathbf{s} \mathbf{s}^T \right\|^2}{a} \left\{ \Gamma(2 - \Gamma) \left\| \tilde{\mathbf{W}} \right\|^2 - \Gamma^2 W_M^2 \right\}
\end{aligned}$$

Define

$$\mathbf{h} = (1 + \mathbf{a}^T \mathbf{s}) I + \mathbf{r}^{-1} \left(\mathbf{a}^T \mathbf{s} + \Gamma \left\| I - \mathbf{a} \mathbf{s} \mathbf{s}^T \right\| \right)^2 > 0 \quad (32) \text{ and}$$

$$\mathbf{g} = \mathbf{h} + \mathbf{b}^{-1} \mathbf{r}^{-1} (1 + \mathbf{a}^T \mathbf{s}) \left(\mathbf{a}^T \mathbf{s} + \Gamma \left\| I - \mathbf{a} \mathbf{s} \mathbf{s}^T \right\| \right)^2 > 0$$

$$r_1 = 2 - (\mathbf{a}^T \mathbf{s})^2 + 2 \mathbf{a}^T \mathbf{s} K_{v \min} - (\mathbf{h} + 2) K_{v \max}^2 > 0$$

which are true because of conditions (28),(30),(31),(32) and (33)

$$r_2 = \Gamma \left\| I - \mathbf{a} \cdot \mathbf{s} \cdot \mathbf{s}^T \right\| \left[\left\| \mathbf{b}^{-1} \mathbf{r}^{-1} \left(\mathbf{a}^T \mathbf{s} + \Gamma \left\| I - \mathbf{a} \mathbf{s} \mathbf{s}^T \right\| \right)^2 + 1 \right\| \right].$$

$$\mathbf{s}_M W_M K_{v \max} + \mathbf{g} K_{v \max} \mathbf{e}_M + (\mathbf{g} + 2) K_{v \max} + \mathbf{a} \mathbf{s}_M^T D_M$$

$$r_3 = \mathbf{g} \left[1 + \left\| \mathbf{b}^{-1} \left(1 + \mathbf{a}^T \mathbf{s} \right) \right\| \right] (D_M + \mathbf{e}_M)^2 + 2D_M^2 +$$

$$+ 2\Gamma \left\| I - \mathbf{a} \cdot \mathbf{s} \cdot \mathbf{s}^T \right\| \left[1 + \left\| \mathbf{b}^{-1} \left(1 + \mathbf{a}^T \mathbf{s} \right) \right\| \right].$$

$$\left[1 + \left\| \mathbf{r}^{-1} \mathbf{b}^{-1} \left(\mathbf{a}^T \mathbf{s} + \Gamma \left\| I - \mathbf{a} \mathbf{s} \mathbf{s}^T \right\| \right)^2 \right\| \right] \cdot (D_M + \mathbf{e}_M) W_M \mathbf{s}_M +$$

$$+ \frac{\left\| I - \mathbf{a} \cdot \mathbf{s} \cdot \mathbf{s}^T \right\|^2}{a} \Gamma^2 W_M^2 +$$

$$\left\| \mathbf{b}^{-1} \Gamma^2 \left\| I - \mathbf{a} \mathbf{s} \mathbf{s}^T \right\|^2 \left[1 + \left\| \mathbf{r}^{-1} \mathbf{b}^{-1} \left(\mathbf{a}^T \mathbf{s} + \Gamma \left\| I - \mathbf{a} \mathbf{s} \mathbf{s}^T \right\| \right)^2 \right\| \right] \right\| \mathbf{s}_M^2 W_M^2$$

Substituting and bounding the term

$$\Delta J < -r_1 \|r\|^2 + 2r_2 \|r\| + r_3 - \frac{\left\| I - \mathbf{a} \cdot \mathbf{s} \cdot \mathbf{s}^T \right\|^2}{a} \Gamma(2 - \Gamma) \left\| \tilde{\mathbf{W}} \right\|^2$$

Completing squares for $\|r\|$

$$\Delta J < -r_1 \left[\|r\| - \frac{r_2}{r_1} \right]^2 + \frac{r_2^2}{r_1} + r_3 - \frac{\left\| I - \mathbf{a} \cdot \mathbf{s} \cdot \mathbf{s}^T \right\|^2}{a} \Gamma(2 - \Gamma) \left\| \tilde{\mathbf{W}} \right\|^2$$

which is negative as long as

$$\left\| \tilde{\mathbf{W}} \right\| > \frac{1}{\left\| I - \mathbf{a} \cdot \mathbf{s} \cdot \mathbf{s}^T \right\| \sqrt{\frac{a(r_2^2 + r_1 r_3)}{r_1 \Gamma(2 - \Gamma)}}} \quad \text{or} \quad \|r\| > \frac{r_2 + \sqrt{r_2^2 + r_1 r_3}}{r_1}$$

From the above results, ΔL is negative outside a compact set. According to a standard Lyapunov theorem extension [12], the tracking error $r(k)$, the actuator error $\tilde{\mathbf{f}}(k)$ and the NN weights estimates $\tilde{\mathbf{W}}(k)$ are globally uniformly ultimately bounded (GUUB).

References

- [1] A. R. Barron, "Universal approximation bounds for superposition of a sigmoidal function," *IEEE Trans. Inform. Theory*, vol. 39, no. 3, pp. 930-945, 1993.
- [2] C. I. Byrnes and W. Lin, "Losslessness, feedback equivalence, and the global stabilization of discrete-time nonlinear systems," *IEEE Transactions of Automatic Control*, vol. 39, no. 1, pp. 83-98, January 1994.
- [3] J. Campos, F. L. Lewis, and R. Selmic, "Backlash compensation in discrete time nonlinear systems using dynamic inversion by neural networks: A preliminary approach," *submitted to the special issue on Developments in Intelligent Control for Industrial Applications of the Int. Journal of Adaptive Control and Signal Processing*, November, 1999.
- [4] J. Campos and F. L. Lewis, "Deadzone compensation in discrete time using adaptive fuzzy logic," *Proc. IEEE Conference on Decision and Control*, pp. 2920-2926, Tampa, FL, 1998.
- [5] M. Grundelius and D. Angelli, "Adaptive control of systems with backlash acting on the input," *Proceedings of the 35th Conference on Decision and Control*, pp. 4689-4694, Kobe, Japan, 1996.

- [6] V. Gullapalli, J. A. Franklin, and H. Benbrahaim, "Acquiring robot skills via reinforcement learning," *IEEE Cont. Syst.*, pp. 13-24, February 1994.
- [7] W. M. Haddad, J. L. Fausz, and V. Chellaboina, "Optimal discrete-time control for nonlinear cascade systems," *Proceedings of the American Control Conference*, pp. 2175-2176, Albuquerque, NM, 1997.
- [8] C. W. Han and Y. X. Zhong, "Robust adaptive control of time-varying systems with unknown backlash nonlinearity," *Proceedings of the American Control Conference*, pp. 763-767, Albuquerque, NM, 1997.
- [9] S. Jagannathan, and F.L. Lewis, "Discrete-Time Control of a Class of Nonlinear Dynamical Systems," *Int. Journal of Intelligent Control and Systems*, vol. 1, no. 3, pp. 297-326, 1996.
- [10] S. Jagannathan, "Robust backstepping control of robotic systems using neural networks," *Proc. Of the IEEE Conf. on Decision & Control*, pp. 943-948, December 1998.
- [11] J. Leitner, A. Calise and J. V. R. Prasad, "Analysis of adaptive neural networks for helicopter flight control," *Journal of Guidance, Control, and Dynamics*, vol. 20, no. 5, pp. 972-979, Sep.-Oct. 1997.
- [12] F. L. Lewis, C. T. Abdallah, and D. M. Dawson, *Control of Robot Manipulators*, MacMillan, New York, 1993.
- [13] F. L. Lewis, A. Yesildirek, and K. Liu, "Neural net robot controller with guaranteed tracking performance," *IEEE Trans. Neural Networks*, vol. 6, no. 3, pp. 703-715, 1995.
- [14] M. B. McFarland and A. J. Calise, "Multilayer neural network and adaptive nonlinear control of agile anti-air missiles," *Preprint*, 1999.
- [15] R. Selmic and F. L. Lewis, "Backlash Compensation in Nonlinear Systems using Dynamic Inversion by Neural Networks," *To appear at the Conference in Control and Automation*, Kona, Hawaii, August 1999.
- [16] R. Selmic and F. L. Lewis, "Deadzone compensation in nonlinear systems using neural networks," *Proc. IEEE Conference Decision and Control*, Tampa, FL, 1998.
- [17] Y. D. Song, T. L. Mitchell, and H. Y. Lai, "Control of a class of nonlinear uncertain systems via compensated inverse dynamics approach," *IEEE Trans. Automatic Control*, vol. 39, no. 9, pp. 1866-1871, September 1994.
- [18] G. Tao and P. V. Kokotovic, *Adaptive Control of Systems with Actuator and Sensor Nonlinearities*, John Wiley & Sons, Inc., New York, 1996.
- [19] G. Tao and P. V. Kokotovic, "Continuous-time adaptive control of system with unknown backlash," *IEEE Trans. Automatic Control*, vol. 40, no. 6, pp. 1083-1087, June 1995.
- [20] G. Tao and P.V. Kokotovic, "Discrete-time adaptive control of systems with unknown nonsmooth input nonlinearities," *Proceedings of the 33rd Conference on Decision and Control*, pp. 1171-1176, Lake Buena Vista, FL, 1994.
- [21] G. Tao and P.V. Kokotovic, "Discrete-time adaptive control of nonlinear systems with unknown deadzones," *Int. J. Control*, vol. 61, no. 1, pp. 1-17, 1995.
- [22] P.-C. Yeh and P. Kokotovic, "Adaptive control of a class of nonlinear discrete-time systems," *International Journal of Control*, vol. 62, no. 2, pp. 303-324, 1995.
- [23] Y. Zhang and Y. C. Soh, "Robust adaptive control of uncertain discrete-time systems," *Automatica*, pp. 321-329, September 1998.