

Takagi-Sugeno Fuzzy Control of DC-DC Boost Converter in PV Systems

M. Allouche (1), M. Chaabane (1), M. Souissi (1), D. Mehdi (2) and F. Tadeo (3)

Abstract— This paper deals with the synthesis of a fuzzy controller of DC-DC boost converter by using the integral action performance. First, a bilinear model of the boost converter is developed which is subsequently converted into a Takagi-Sugeno (TS) model. Then, a TS fuzzy controller is designed to stabilize the output voltage and guarantee a perfect disturbance rejection. It should be noted that the boost converter is used as an interface between the photovoltaic (PV) panels and the loads connected to them. Thus, the purpose of the proposed fuzzy controller is to adapt the duty cycle of the power MOSFET even in the case of the input voltage variation, so that the tracking performance is guaranteed. The control gains are obtained by solving a set of Linear Matrix Inequality (LMI). Finally, simulation result is given to demonstrate the controller's effectiveness.

I. INTRODUCTION

The photovoltaic (PV) generator, which originates from solar power, have been widely considered to be a good source of renewable energy because of its direct form of electrical energy, low maintenance, no noise, no pollution, etc [1]. However, one of the major problems of PV generator is that the output voltage of PV panels is highly dependent on solar irradiance and ambient temperature. Consequently, loads cannot be directly connected to the output of PV panels. In this case, a DC-DC converter is required to operate as an interface between PV panels and loads [2]. It receives variable input voltage, which is the output of PV panels, and yields constant output voltage across its output capacitors where the loads can be connected. Currently, the problem of control for DC-DC converter has been dealt with several approaches and many studies have been developed around this subject. Among them, we can mention: traditional PI control, sliding-mode control, state feedback-linearizing control, fuzzy control... The PI control law design can only assure stability and dynamic performances around equilibrium point, and hence, instabilities or bad performances may appear when large signal perturbations

This work was funded by the AECID project A/023792/09 and A/030410/10.

The authors are with the Laboratory of Sciences and Techniques of Automatic Control & Computer Engineering (Lab-STA), National School of Engineering of Sfax, University of Sfax. Postal Box 1173, 3038 Sfax, Tunisia. E- mails: Moez_allouche@yahoo.fr.

Mehdi Driss is a Professor with the Laboratory LIAS, ENSIP, University of Poitiers, 2 rue Pierre Brousse, Bât. B25- BP 633, 86022, Poitiers, France. E-mail: Driss.Mehdi@univ-poitiers

Fernando Tadeo is a Professor with the Department of systems Engineer in the University of Valladolid, 47011 Valladolid, Spain. E-mail: fernando@autom.uva.es

occur [3]. The control method based on linearization techniques present a poor dynamic performance and the implantation of this kind of nonlinear control laws for high frequency signal is difficult [4]. Sliding mode technique has been widely used in the converter control and proved a small tracking error, but chattering phenomenon is inevitable which degrades performances of the system and may even lead to instability [5]. Recently, substantial research efforts have been devoted to intelligent controllers such as artificial neural networks and fuzzy logic to deal with the problems of nonlinearity and uncertainly applied to the control of power electronic converters [6, 7, 8, 9, 10]. Among various fuzzy modeling methods, the well-known Takagi-Sugeno (T-S) fuzzy model is considered as a popular and powerful tool in approximating a complex non linear system [11, 12]. They correspond to a collection of linear models blended together with weighting functions. These functions are positive scalar whose sum was assumed to be equal to unity for all linear submodels and stability is ensured if there exists a common quadratic Lyapunov function for all linear submodels [13].

In this paper, we will apply T-S fuzzy modeling approach to the design of fuzzy controller for DC-DC boost converter in witch an integrator action is added. The proposed controller can guarantee stability, good dynamic behavior and zero tracking error when the exogenous signals are constant. The controller gains are parameterized in terms of a linear matrix inequality problem which can be solved very efficiently.

This paper is organized as follows: in section II, the characteristics of solar panels are presented. In section III, a bilinear model of the boost converter is proposed from which, a Takagi-Sugeno fuzzy model is derived. Section IV presents the design of a fuzzy controller with integral action performance. Section V shows the simulation results of the boost converter in which a comparison with a PI-controller in terms of the transient's response is given to demonstrate the merits of the proposed fuzzy control approach. The last section gives a conclusion on the main themes developed in this paper.

II. CHARACTERISTICS OF SOLAR PANELS

Solar panels consist of different solar cells connected in series and/or parallel in order to achieve desired voltage and current levels. The solar cell is equivalent to a light current generated connected in parallel with a diode D , and a shunt resistor, and all are coupled to a series resistor. This electrical model has the ability to convert solar radiation into

DC current. This is called the PV effect. The output current of the PV array is given by

$$I = I_{ph} - I_0 \left[e^{\frac{q(V+R_s I)}{nKT}} - 1 \right] - \frac{V + R_s I}{R_{sh}} \quad (1)$$

- I_{ph} Light generated current
- I_0 Reverse saturation current
- q Electronic charge
- K Boltzmann's constant
- T Cell temperature
- R_s Series resistance of the cell
- R_{sh} Shunt resistance of the cell

The equivalent circuit of the PV panel is presented in Fig. 1.

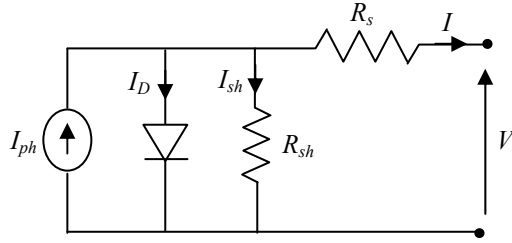

Fig. 1. Panel circuit model

According to the equation (1), Fig. 2 and 3 depicts the characteristics of the PV current with respect to the PV voltage for different value of solar irradiation E (W/m^2) and cell temperature T ($^{\circ}C$).

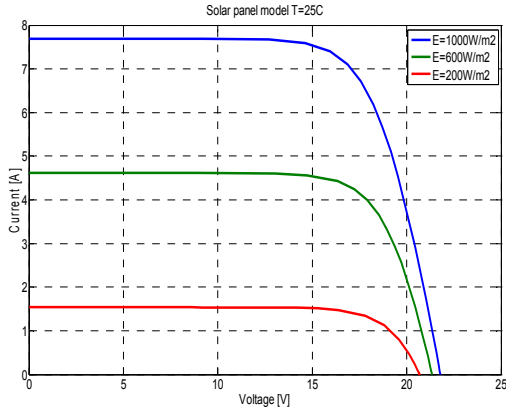

Fig. 2. LC120-12P PV module current – voltage curve when the irradiation is 200, 600 and 1000 W/m^2

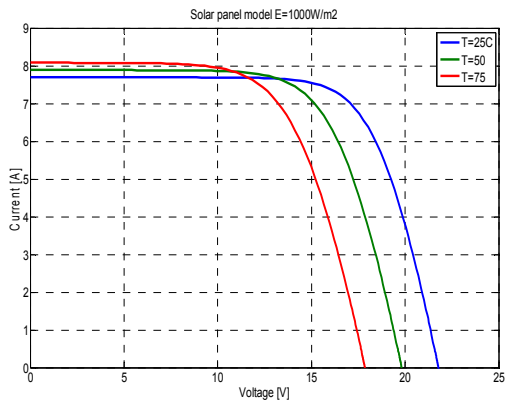

Fig. 3. LC120-12P PV module current – voltage curve when the temperature is 25, 50 and 75 $^{\circ}C$.

We can easily note that the output voltage of PV panels is variable and extensively depending on solar irradiation and cell temperature conditions. However, a constant voltage level is needed for connecting loads to PV panels. This imposes necessarily an interface between PV panels and loads like the proposed boost converter.

I. TAKAGI-SUGENO FUZZY MODEL OF A BOOST CONVERTER

In this section, we review the averaged bilinear model of the converter to infer a Takagi-Sugeno model that we will use in the fuzzy control design step. The circuit diagram of the boost converter is shown in Figure (4).

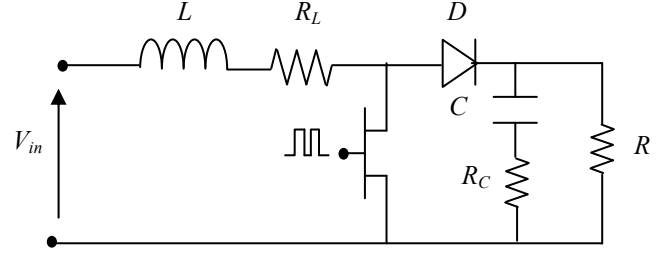

Fig. 4. Circuit diagram of the boost converter

A. Bilinear model

The voltage mode controlled boost converter circuit is governed by two sets of linear differential equations pertaining to the ON and OFF states of the controlled switch. If the output voltage and the inductor current are taken as state variables, the state equations during the "ON" period can be defined as:

$$\begin{cases} \frac{dv_c(t)}{dt} = -\frac{I}{(R+R_c)C} v_c(t) \\ \frac{di_L(t)}{dt} = -\frac{R}{L} i_L(t) + \frac{V_{in}}{L} \end{cases} \quad (2)$$

And during the "OFF" period, the equations are:

$$\begin{cases} \frac{dv_c(t)}{dt} = -\frac{I}{(R+R_c)C} v_c(t) + \frac{R}{(R+R_c)C} i_L(t) \\ \frac{di_L(t)}{dt} = -\frac{R}{(R+R_c)L} v_c(t) - \left[\frac{R_L}{L} + \frac{RR_C}{(R+R_c)L} \right] i_L(t) + \frac{V_{in}}{L} \end{cases} \quad (3)$$

where R_L and R_C are the parasitic resistances of the inductor and capacitor. In a boost converter, the output voltage is always higher than the input voltage. Indeed, when the controlled switch is turned on, the current through the inductor increases and the latter stores the energy while the diode is reverse biased leading to the disconnection of the load (R) and the output capacitor (C) from the source voltage. When the controlled switch is turned off, the polarity of the inductor voltage changes reducing the inductor current and charging the capacitor to a voltage higher than the input voltage. Consequently, the boost converter's dynamic behaviour during T_{on} and T_{off} can be expressed as follows:

$$\dot{x}(t) = H_k x(t) + D_k \quad k=1,2 \quad (4)$$

Being,

$$H_1 = \begin{bmatrix} -\frac{I}{(R+R_c)C} & 0 \\ 0 & -\frac{R_L}{L} \end{bmatrix}, H_2 = \begin{bmatrix} \frac{I}{(R+R_c)C} & \frac{R}{(R+R_c)C} \\ \frac{R}{(R+R_c)L} & \left[\frac{R_L}{L} + \frac{RR_c}{(R+R_c)L} \right] \end{bmatrix}$$

$$D_1 = D_2 = \begin{bmatrix} 0 \\ \frac{V_{in}}{L} \end{bmatrix} \text{ and } x(t) = \begin{bmatrix} v_c(t) \\ i_L(t) \end{bmatrix}$$

The states variables $v_c(t)$ and $i_L(t)$ are susceptible for the measurement and available for the feedback control.

A binary signal d , turns on and off the switches periodically, since we consider a PWM modulation. T_s is the switching period equal to the sum of T_{on} and T_{off} .

Equation (4) can be expressed in compact form as follows:

$$\dot{x}(t) = [H_1 x(t) + D_1]d + [H_2 x(t) + D_2][1-d] \quad (5)$$

or, equivalently:

$$\dot{x}(t) = H_2 x(t) + (H_1 - H_2)x(t)d + D_1 \quad (6)$$

where $d=1$ during T_{on} and $d=0$ during T_{off} .

The duty cycle $u(t)$ is the ratio given as follows:

$$u(t) = \frac{T_{on}}{T_s} \quad (7)$$

Considering that the switching frequency is significantly higher than the converter natural frequencies. Equation (4) can be expressed as a bilinear model:

$$\dot{x}(t) = H_2 x(t) + (H_1 - H_2)x(t)u(t) + D_1 \quad (8)$$

or

$$\dot{x}(t) = H_2 x(t) + (B(x(t))u(t) + D_1) \quad u(t) \in [0, 1] \quad (9)$$

Where

$$B(x(t)) = \begin{bmatrix} -\frac{Ri_L(t)}{(R+R_c)C} \\ \frac{Rv_c(t) + RR_c i_L(t)}{L(R+R_c)} \end{bmatrix}$$

and $u(t)$ is the control input.

In the next subsection, we rewrite the incremental bilinear converter model by a Takagi-Sugeno representation.

B. Takagi-Sugeno model of the Boost Converter

The Takagi-Sugeno model is considered as an exact representation of the non linear systems which can describe the dynamic of the system by means of an interpolation of linear submodels. The performance requirements of a linear model may be expressed by means of LMI.

According to the bilinear model (9) of the boost converter, we consider the sector of nonlinearities of the terms $z_k(t) = x_k(t) \in [z_{k,min}, z_{k,max}]$ of the matrix $A(x(t))$ with $k=1, 2$:

$$\begin{cases} z_1(t) = v_c(t) \\ z_2(t) = i_L(t) \end{cases} \quad (10)$$

Thus, we can transform the nonlinear terms under the following shape:

$$z_k(t) = F_{k,min}(z_k(t)) \cdot z_{k,max} + F_{k,max}(z_k(t)) \cdot z_{k,min} \quad (11)$$

Where the membership functions are defined as follows:

$$\begin{cases} F_{k,min}(z(t)) = \frac{z_k(t) - z_{k,min}}{z_{k,max} - z_{k,min}} \\ F_{k,max}(z(t)) = 1 - F_{k,min}(z(t)) = \frac{z_{k,max} - z_k(t)}{z_{k,max} - z_{k,min}} \end{cases} \quad (12)$$

The fuzzy model is described by fuzzy *If-Then* rules and will be employed here to deal with the control design problem for the boost converter. The converter fuzzy model is described by four rules:

- **Rule 1**

$$\begin{aligned} &\text{If } v_c(t) \text{ is } F_{1,min} \text{ and } i_L(t) \text{ is } F_{2,min} \\ &\text{Then } \dot{x}(t) = A_1 x(t) + B_1 u(t) + D_1 \end{aligned} \quad (13)$$

- **Rule 2**

$$\begin{aligned} &\text{If } v_c(t) \text{ is } F_{1,min} \text{ and } i_L(t) \text{ is } F_{2,max} \\ &\text{Then } \dot{x}(t) = A_2 x(t) + B_2 u(t) + D_1 \end{aligned} \quad (14)$$

- **Rule 3**

$$\begin{aligned} &\text{If } v_c(t) \text{ is } F_{1,max} \text{ and } i_L(t) \text{ is } F_{2,min} \\ &\text{Then } \dot{x}(t) = A_3 x(t) + B_3 u(t) + D_1 \end{aligned} \quad (15)$$

- **Rule 4**

$$\begin{aligned} &\text{If } v_c(t) \text{ is } F_{1,max} \text{ and } i_L(t) \text{ is } F_{2,max} \\ &\text{Then } \dot{x}(t) = A_4 x(t) + B_4 u(t) + D_1 \end{aligned} \quad (16)$$

Where

$$A_1 = A_2 = A_3 = A_4 = H_2$$

$$B_1 = \begin{bmatrix} -\frac{Ri_{L,min}}{(R+R_c)C} \\ \frac{Rv_{cmin} + RR_c i_{L,min}}{L(R+R_c)} \end{bmatrix}, B_2 = \begin{bmatrix} -\frac{Ri_{L,max}}{(R+R_c)C} \\ \frac{Rv_{cmin} + RR_c i_{L,max}}{L(R+R_c)} \end{bmatrix}$$

$$B_3 = \begin{bmatrix} -\frac{Ri_{L,min}}{(R+R_c)C} \\ \frac{Rv_{cmax} + RR_c i_{L,min}}{L(R+R_c)} \end{bmatrix}, B_4 = \begin{bmatrix} -\frac{Ri_{L,max}}{(R+R_c)C} \\ \frac{Rv_{cmax} + RR_c i_{L,max}(t)}{L(R+R_c)} \end{bmatrix}$$

The global fuzzy model is inferred as follows:

$$\dot{x}(t) = \sum_{i=1}^4 h_i(z(t)) (A_i x(t) + B_i u(t) + D_i) \quad (17)$$

Where

$$h_i(z(t)) = \frac{\lambda_i(z_1, z_2)}{\sum_{i=1}^4 \lambda_i(z_1, z_2)} \quad (18)$$

$$\lambda_i(z_1, z_2) = F_{1,l}(z_1(t)) F_{2,f}(z_2(t)) \quad l, f \in \{\min, \max\} \quad (19)$$

$$\sum_{i=1}^r h_i(z(t)) = 1 \quad (20)$$

It should be noted that the global fuzzy model (17) is equivalent to the bilinear system (4) inside the polytope region $[i_{L,\min}, i_{L,\max}] \times [v_{c,\min}, v_{c,\max}]$. In next section, we propose a fuzzy based controller that adapts the duty cycle $u(t)$ to the perturbation that affect the input voltage such that the output voltage remains constant.

II. TS FUZZY CONTROLLER FOR THE BOOST CONVERTER

After obtaining the TS fuzzy model of the boost converter, we propose to design the TS fuzzy controller for the converter with guaranteed stability and good dynamic behavior [14]. The main difference from the ordinary PDC controller described in [12] is to add in the control law a term of integral of the output voltage tracking error [8]:

$$e_i = \int (V_{ref} - v_{out}(t)) dt \quad (21)$$

It should be noted that the capacitor resistance R_c is negligible with respect to the loading resistance R , so we can consider that $v_{out}(t) \approx v_c(t)$ in permanent regime. Consequently, the expression of the output voltage tracking error becomes:

$$e_i = \int (V_{ref} - v_c(t)) dt \quad (22)$$

The TS-fuzzy plant model of (17) is augmented as,

$$\dot{\bar{x}}(t) = \sum_{i=1}^4 h_i(z(t)) (\bar{A}\bar{x}(t) + \bar{B}_i u(t) + \bar{D}\bar{w}(t)) \quad (23)$$

Where

$$\bar{A} = \begin{bmatrix} A_i & 0 \\ -C & 0 \end{bmatrix}, \quad \bar{B}_i = \begin{bmatrix} B_i \\ 0 \end{bmatrix}, \quad \bar{D} = \begin{bmatrix} 0 & 0 \\ I & 0 \\ 0 & I \end{bmatrix}, \quad \bar{w}(t) = \begin{bmatrix} V_{in} \\ V_{ref} \end{bmatrix},$$

$$\bar{x} = \begin{bmatrix} x(t) \\ e_i \end{bmatrix} \text{ and } C = [I \ 0].$$

A four-rule fuzzy controller employing the same membership functions of the TS-fuzzy plant model of (17) will be used to control the converter. The rules of the fuzzy controller are as follows:

Rule R_i

If $v_c(t)$ is F_{1i} and $i_L(t)$ is F_{2j}

then $u(t) = \bar{K}_i \bar{x}(t)$ $l, f \in \{\min, \max\}$ (24)

where \bar{K}_i are linear feedback gain vectors associate with each rule. And the overall fuzzy controller is represented as:

$$u(t) = \sum_{i=1}^4 \bar{K}_i \bar{x}(t) \quad (25)$$

Substituting the control law (25) in the fuzzy model (23), the closed loop system is given by:

$$\dot{\bar{x}}(t) = \sum_{i=1}^4 \sum_{j=1}^4 h_i(z(t)) h_j(z(t)) (\bar{A} + \bar{B}_i \bar{K}_j) \bar{x}(t) + \bar{D}\bar{w}(t) \quad (26)$$

$\bar{w}(t)$ denotes the disturbance due to the input voltage variation. To deal with the problem of disturbance effect, the H_∞ performance is represented as follows: given a disturbance attenuation level ρ , the H_∞ control problem is said to be solved if there exists a control law such that the following H_∞ performance can be achieved [15, 16].

$$\int_0^t \bar{x}^T(t) \bar{x}(t) dt \leq \rho^2 \int_0^t \bar{w}^T(t) \bar{w}(t) dt \quad (27)$$

The feedback gains are determined by an LMI-based design technique addressed in the following theorem.

Theorem

Consider the TS fuzzy model (23) with the PDC control law (25). The closed loop system is asymptotically stable and achieves H_∞ performance, if there exist matrices $P > 0$, Y and a prescribed positive constant ρ^2 such that:

$$\begin{bmatrix} \bar{A}P + P\bar{A}^T + \bar{B}_i Y_i + Y_i^T \bar{B}_i^T & \bar{D}_i & P \\ \bar{D}_i^T & -\rho^2 & 0 \\ P & 0 & -I \end{bmatrix} < 0 \quad (28)$$

$$\begin{bmatrix} \bar{A}P + P\bar{A}^T + \bar{B}_i Y_j + Y_j^T \bar{B}_i^T + \bar{B}_j Y_i + Y_i^T \bar{B}_j^T & \bar{D}_i & P \\ \bar{D}_i^T & -\rho^2 & 0 \\ P & 0 & -I \end{bmatrix} < 0 \quad (29)$$

The control gains are given by

$$\bar{K}_i = Y_i P^{-1} \quad (30)$$

III. SIMULATION RESULTS

Simulation results have been taken to insure the effectiveness of the proposed control strategy. A block diagram of the TS fuzzy controller with integral action performance is shown in Fig. 5.

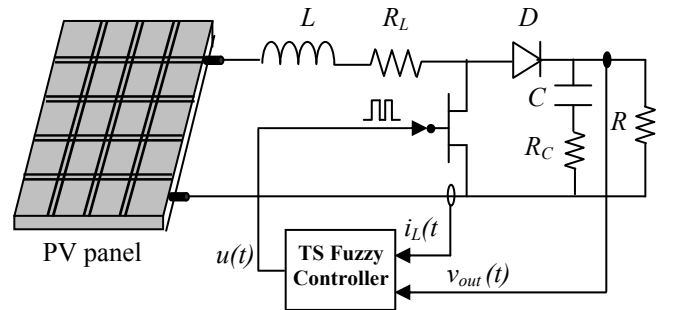

Fig. 5. Bloc diagram of the TS fuzzy controller

The control gains obtained via LMI toolbox are given as follows:

$$K_i = [-0.0402 \quad 1.4931 \quad -41.7717]$$

$$K_2 = [0.0382 \quad -1.4852 \quad 40.9319]$$

$$K_3 = [0.0050 \quad -2.2711 \quad 84.6642]$$

$$K_4 = [0.0653 \quad -5.7318 \quad 182.2712]$$

The symmetric positive-definite P is:

$$P = \begin{bmatrix} 0.0028 & -0.0045 & -0.0026 \\ -0.0045 & 0.2578 & -1.0540 \\ -0.0026 & -1.0540 & 235.7977 \end{bmatrix}$$

To verify the performance of the boost converter controlled by the integral TS fuzzy controller, variations of the input voltage is considered. However, the converter input voltage is provided by the PV panel, which depends on the solar irradiation and temperature of the photovoltaic cell. Fig.6. represents the choice of three operating points, that due to the variation of the input voltage converter. The change of the input voltage from P_1 (13V) to P_2 (17.1 V) is due to the variation of solar irradiation, which increases from $600\text{W}/\text{m}^2$ to $1000\text{W}/\text{m}^2$. We suppose that the cell temperature is held constant at 25°C . In the same way, the change of the voltage from P_2 (17.1) to P_3 (16V), is caused by the variation of the temperature of the photovoltaic cell passing from 25°C to 50°C . This passage is obtained with a constant solar irradiation of value $1000\text{W}/\text{m}^2$.

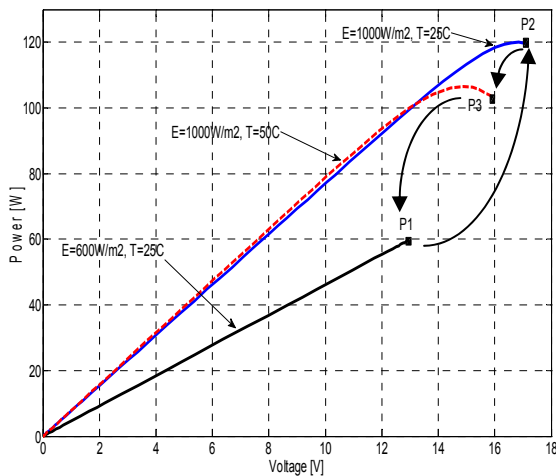

Fig. 6. The input voltage changing: $P_1 \rightarrow P_2 \rightarrow P_3 \rightarrow P_1$, owing to the solar irradiation and cell temperature variation

Fig. 7-b illustrate the output voltage response controlled by the designed TS fuzzy controller when the boost converter is subject to the predefined input voltage changing (Fig. 7-a). The output voltage converges perfectly to the desired trajectory and did not get affected by the solar irradiation and cell temperature variation. A short settling time and a small overshoot which not pass 10% is detected due to the variation of the input voltage. A zero static error is illustrated in Fig. 7-b what proves the integral action performance in the proposed T-S fuzzy controller.

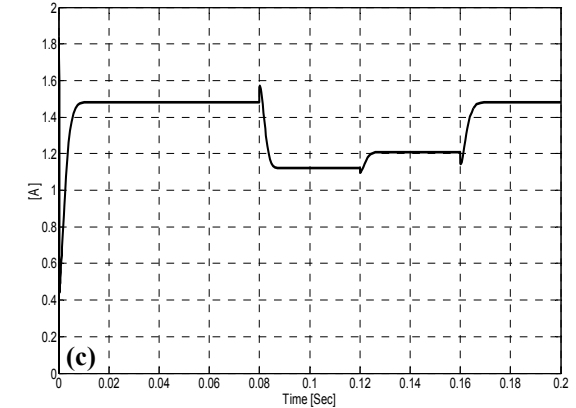
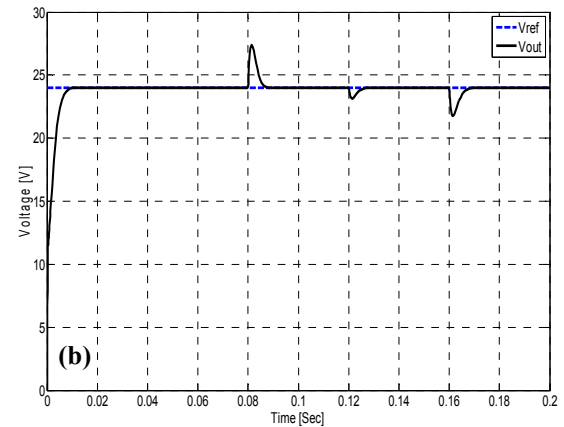
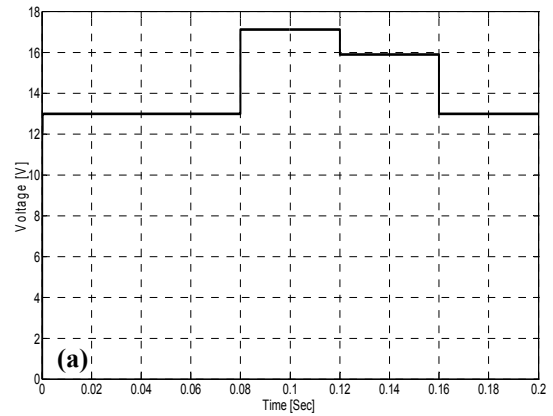

Fig. 7-a. The input voltage variation V_{IN}

Fig. 7-b. The output voltage $v_c(t)$ for fuzzy controller

Fig. 7-c. The inductor current $i_L(t)$ for fuzzy controller

To demonstrate the performance of the proposed fuzzy controller, a classical PI controller is employed to control the same plant for comparison. The output of the PI controller is given by $u(t) = K_p e(t) + K_i \int e(t) dt$, where $K_p = 0.001$ is the proportional gain and $K_i = 5$ is the integral gain. The same input voltage change is applied to the PI controlled boost converter, in which the response of the output voltage and the inductor current are illustrated in

the Fig. 8.

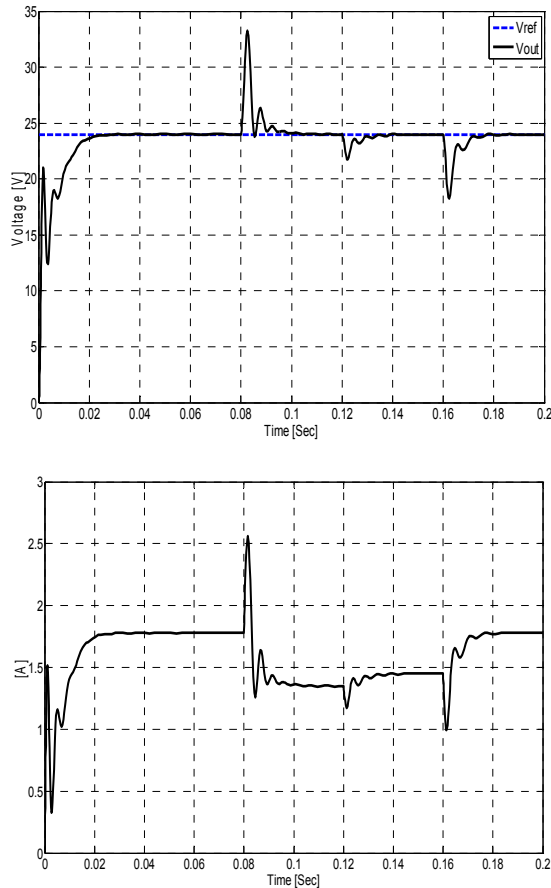

Fig. 8. Voltage and current response of the PI controlled boost converter subject to the same input voltage changing.

By analyzing the voltage response of the PI controlled boost converter, it can be seen that the latter presents an important oscillations and ripple in transient regime, what prove that the fuzzy controller gives a better performance than the PI controller.

IV. CONCLUSION

In this paper, a nonlinear fuzzy controller for the control of the DC-DC boost converter connected in PV systems has been presented. The Takagi-Sugeno (TS) fuzzy modeling for nonlinear system is firstly proposed. Based on this fuzzy plant model, an integral fuzzy controller has been designed with guaranteed stability and good dynamic behavior for a PWM boost converter. The control gains are obtained by solving a set of LMIs and the disturbance rejection is further guaranteed using the H_∞ criterion. The static converter is subject to the input voltage change, due to the variation of the solar irradiation and of the temperature of the photovoltaic cell. The simulation results show that fuzzy controller can achieve better control performance defined by a good transient responses and a less sensibility to the

disturbance effect than a PI controller.

APPENDIX

The parameters of the boost converter are listed as below:

Inductor	:	$L = 0.5mH$
Capacitor	:	$C = 47\mu F$
Inductor resistor	:	$R_L = 0.01\Omega$
Capacitor resistor	:	$R_C = 0.01\Omega$
Load resistor	:	$R = 30\Omega$

REFERENCES

- [1] P. Nema, R. K. Nema, and S. Rangnekar, "A current and future state of art development of hybrid energy system using wind and PV-solar: A review," *Renewable Sustainable Energy Rev.*, vol. 13, no. 8, pp. 2096–2103, 2009.
- [2] M. Elshaer, A. Mohamed and O. Mohamed, "Smart Optimal Control of DC-DC Boost Converter in PV Systems," *IEEE/PES Transmission and Distribution Conference and Exposition*, pp. 403-410, 2009.
- [3] C.A.T. Pinzon, R. Leyva, "Fuzzy Control in DC-DC Converters: an LMI Approach," *35th Annual Conference of IEEE Industrial Electronics. IECON '09*, pp. 510–515, 3-5 November. 2009.
- [4] H.J.S. Ramirez, R.A.P. Moreno, R. Ortega, and M.G. Esteban "Passivity-based controllers for the stabilization of DC to DC converters," *Automatica*, Vol. 33, No. 4, pp. 499-513, 1997.
- [5] E. Fossas, L. M. Salamero, and J. Ordinas, "Sliding mode control reduces audiosusceptibility and load perturbations in the Cuk converter," *IEEE Transactions on Circuits and Systems Fundamental I: Theory Applications*. Vol. 39, No. 6, October 1992, pp. 847-849
- [6] H. K. Lam, F. H. F. Leung, and P. K. S. Tam, "Fuzzy Control of Dc-Dc Switching Converters Based on TS-Modeling Approach," *Proc. 24th Annual Conference of the IEEE Industrial Electronics Society (IECON '98)*, Aachen, Sept. 1998, pp. 1052-1054, Germany.
- [7] H. K. Lam, T.H. Lee, F. H. F. Leung, and P. K. S. Tam, "Fuzzy Control of Dc-Dc Switching Converters: Stability and robustness analysis," *The 27th Annual Conference of the IEEE Industrial Electronics Society (IECON '01)*, pp. 899-902.
- [8] K.Y. Lian, J.J. Liou, and C.Y. Huang, "LMI-Based Integral Fuzzy Control of DC-DC Converters," *IEEE transactions on fuzzy systems*, vol. 14, No. 1, pp. 71-80, 2006.
- [9] Y. Li and Z. Ji, "An Approach on T-S Fuzzy Model and Control of Buck-boost Converter," *Proceedings of the 7th World Congress on Intelligent Control and Automation*, PP. 91-96, 2008, China.
- [10] M.O. Yatak O.F. Bay, "Fuzzy Control of a Grid Connected Three Phase Two Stage Photovoltaic System," *Proceedings of the 2011 International Conference on Power Engineering, Energy and Electrical Drives. Torremolinos (Málaga)*, Spain. May 2011.
- [11] Takagi, Sugeno, 1985, "Fuzzy identification of systems and its applications to modelling and control," *Conference on Systems, Man and Cybernetics*, 15, 1985.
- [12] K. Tanaka and H.O. Wang, "Fuzzy Regulators and Fuzzy Observers: A Linear Matrix Inequality Approach," *Proceedings of the 36th Conference on Decision & Control San Diego, California USA*, vol. 5, no. 50, pp. 1315–1320, 1997.
- [13] H.Wang, K.Tanaka and M.Griffin, "An approach to fuzzy control of nonlinear systems: Stability and design issues". *IEEE Transaction on Fuzzy Systems*, vol. 4, pp.14-23, 1996.
- [14] T.M.Guerra and J.Lauber "Control laws for Takagi-Sugeno fuzzy models" *Fuzzy sets and systems*, pp. 95-108, 2001.
- [15] Tseng,C., Bor-sen Chen, Uang, H.J "Fuzzy tracking control design for non linear dynamic system via TS fuzzy model". *IEEE Trans, fuzzy, sys*, vol.9 pp381-392 (2001).
- [16] Chong. Lin, Q-G. Wang, and T. H. Lee, " H_∞ output tracking control for nonlinear via T-S fuzzy model approach," *IEEE Trans. systems. Cybernetics*, vol. 36, NO. 2, April 2006.